

HERON ELECTRIC COMPANY LTD

Basic User and Installation Manual

MCI-4, MCI-8, MCI-12, MCI-16, and MCI-96



Doc ref.MCI4-96 BASIC-6 March 2003
Basic manual for version 49XXX, controllers

Copy of this manual is at ww.heron-electric.com
Price for a copy to be posted is £10

1. About This Controller

Congratulations, you are now the owner of a Heron MCI irrigation controller.

Your controller will operate 24volt AC* solenoid valves. The controller will run the valves for the length of time, and in the order you specify. This sequence of running solenoid valves is known as an **irrigation program**.

Irrigation programs can be started automatically at pre-set start times. Alternatively, an irrigation program, a single solenoid valve or the pump, can be started manually at any time.

* DC valves can be operated from a DC controller.

2. Wiring Up

Mounting the Controller

The controller should be mounted on a wall using four screws, one screw through each of the corner lid bolt holes.

Wiring Up Your Controller

The MCI-96, MCI-16, MCI-12 and all DC controllers should be wired up as shown in Fig 2.

The MCI-8 and MCI-4 controllers should be wired up as shown in Fig 1 below .

For an MCI-96 with more than 16 valves, wire up the output expansion box to the connector marked "EX".

Connecting Mains Supply: IMPORTANT

Switch off the mains supply before connecting the controller.

Ensure the mains supply voltage is the same as the voltage of the controller. The controller voltage is displayed inside the controller.

As with any equipment used in damp conditions, the mains supply should be fused with a Residual Current Circuit Breaker (3 amp fuse).

Connect the mains supply to the IEC connector as shown in Figs 1 and 2. Connect L to Live, N to Neutral and E to Earth.

Wire the controller directly back to the main distribution panel. This is particularly important when large pumps or inductive electrical loads are also used.

Connecting Solenoid Valves

Connect each solenoid valve to the appropriate output as shown in Figs 1 and 2. The common wire from each solenoid valve should be connected to the "C1" terminal. Valves can be connected in parallel provided the maximum valve output current does NOT exceed the output current rating of the controller.

The solenoid output voltage is an Extra Low Safety Voltage. Keep solenoid cables and connections well away mains voltages as per regulations for Extra Low Safety Voltages .

Connecting Pumps

Two pump control outputs are available, namely "Pump-1" and "Pump-2".

The "Pump-1" output is across the "O1", "C1" terminals. Connect a suitable 24V relay across these terminals to control the pump.

The "Pump-2" output is across "O3" and "C1". Connect a suitable 24V relay across these terminals to control the second pump.

The second pump start output, "Pump-2", operates with irrigation programs 7 to 15.

Surge Earth

If your controller has an surge terminal (marked E1) connect this terminal to a local dedicated earth rod. If this is not possible connect to a good earth.

Fig 1 Wiring for MCI-4 and MCI-8

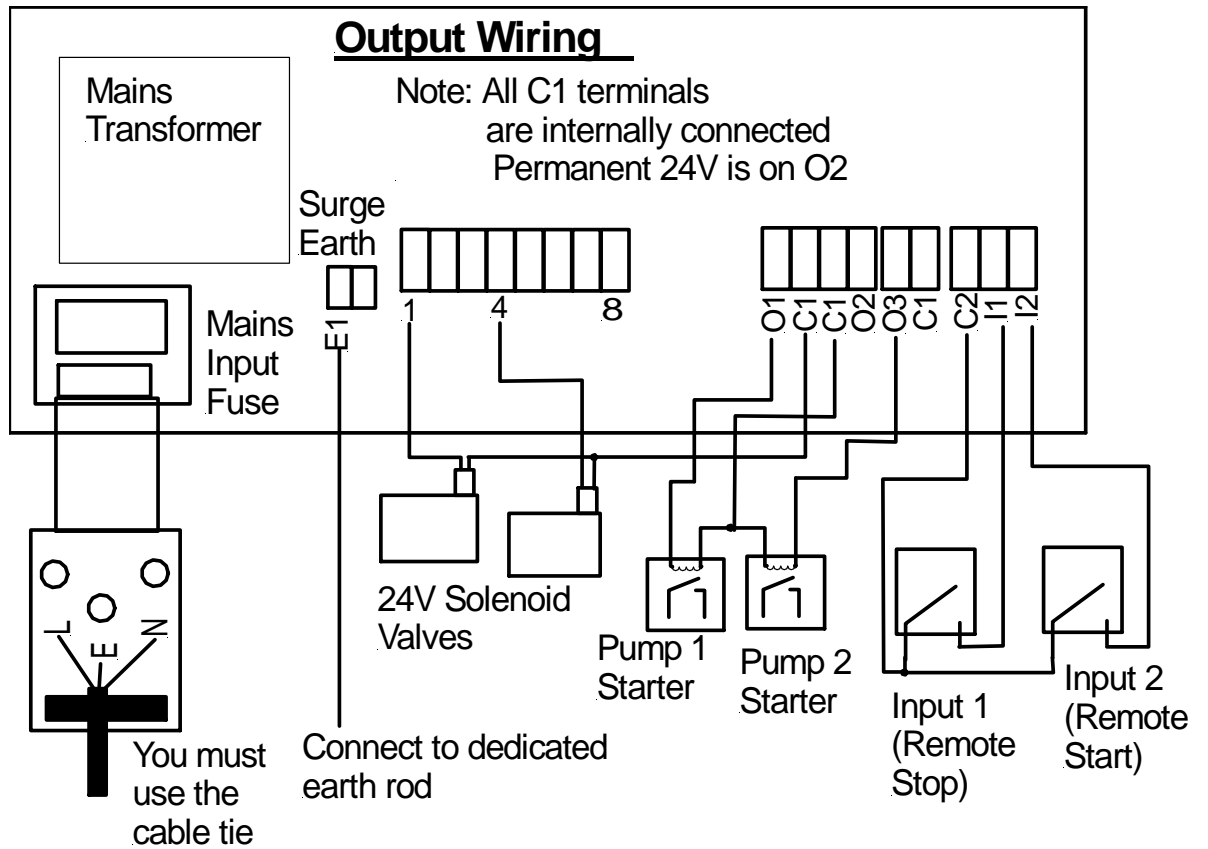
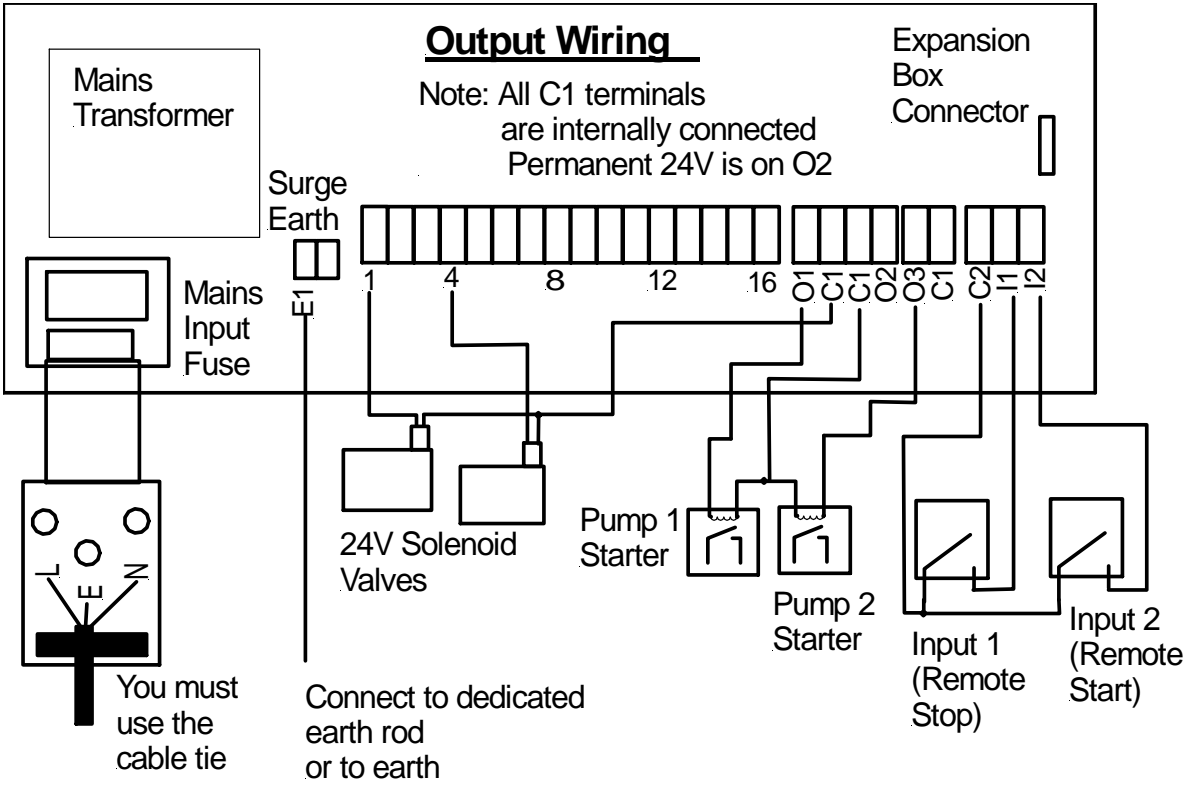

Fig 2 Wiring for MCI-12, MCI-16 and MCI-96



3. More Inputs and Outputs

Remote Start

The remote start input is across "I2" and "C2". Joining these terminals will start program 1. The terminals have to be connected for only a short period, 1 second, to activate the program. If the contacts are left shorted program 1 will continually cycle.

Remote Stop / Low Water Cut Out

The remote stop input is across "I1" and "C2". Joining these inputs halts the irrigation programs. The programs will continue once the short is removed.

This input may be connected to a float switch in the water reservoir so that the irrigation sequence is halted if the water level is low.

24V Output

A 24V supply is permanently available across "O2" and C1".

PC Connection

The PC connection is white 4 Pin connector on the top side of the processor board. (The processor board is mounted in the lid.) Plug a Heron RS232 interface onto this connector (RS232INT-B) to allow your controller to be connected to a PC running Ground Control software.

Interface Board Connection

The Interface Board Connection is Black 10 pin connector in the middle of the processor board. (The Processor board is mounted in the lid.) You can plug the following boards into this connector to allow a variety of sensors to be connected to your MCI controller:-

- Remote Start Expansion Board
- Single Analogue Interface Board
- Multi-Interface Board

When the you switch on the power the **Time Page** is displayed as shown below.

Now **Pressing** '>' shows the first valve Page of Program 1

TIME	VALVES OFF
12:11	

Now **Pressing** '>' shows the next valve page

VALVE 1	2	3
00:00	00:00	00:00

Now **Pressing** '>' shows the next valve page

VALVE 4	5	6
00:00	00:00	00:00

Now **Pressing** '>' shows the Automatic Start Page

VALVE 7	8
00:00	00:00

AUTO	OFF	OFF	OFF
0:00	0:00	0:00	

Now pressing '>' will return you to the Time Page again.

4. Getting to know your controller

5. Your First Irrigation Program

By means of an example this section describes how to set an irrigation program and set an automatic start. The example will set **Valve 1 for 10 minutes, Valve 2 for 5minutes** in irrigation **program 1** and then set an **automatic start** to start the irrigation program at **6.00 am**.

Setting the Irrigation Program

Press '>' until the valve page is displayed as shown below.

With the cursor flashing under **"VALVE 1"**, press "1" and "0" to enter 10 minutes as shown below.

VALVE	1	2	3
10:00	0:00	0:00	

Press the ">" twice to move the cursor under **VALVE 2** and press "5" as shown below.

VALVE	1	2	3
10:00	5:00	0:00	

Setting the Automatic Start Times - The Steps

Press the arrow forward key ">" until the **"Automatic Start Time"** page is displayed.

AUTO	OFF	OFF	OFF
1	0:00	0:00	0:00

With the cursor flashing on the first zero, press the "6" on the keypad to enter a 6:00 am start time.

AUTO	OFF	OFF	OFF
1	6:00	0:00	0:00

You must now activate the start time by pressing the **"Select"** button whilst the flashing cursor is still positioned on the start time You will see the display above the start time change **from "OFF" to "PRG1"**.

AUTO	PRG1	OFF	OFF
1	6:00	0:00	0:00

“**PRG1**” indicates that a start time has been activated as shown above.

To enter a second automatic start time, press the arrow forward key “>” until it is positioned on the first zero of the second start.

Press the arrow forward key “>” to return to the “**Time Page**”.

Congratulations....You have now set up your first irrigation program.

6. Starting and Stopping

To manually start the **pump, a valve or an irrigation program** press 'Start/Stop' and the following page will be displayed.

```
START >PUMP VALVE
          PROG
```

Pump Start

With the flashing arrow pointing at "**PUMP**" press "**Select**" to start Pump 1. The display below will be shown.

```
TIME      PUMP ON
12:30
```

Valve Start

Press the arrow forward key ">" to position the flashing arrow to point at "**VALVE**".

Press "**Select**" and the page below is shown.

```
START VALVE 5 TIME 2
```

Enter the number of the valve to be started.

Press the ">" and then enter the number of minutes the valve is to run.

In the example above valve 5 has been set to run for 2 minutes.

Now press "**Select**" to start this valve. The "**Time Page**" will be displayed as shown below.

```
TIME      VALVE 5 1:58
12:00
```

Program Start

To start an irrigation program press the arrow forward key ">" to move the flashing arrow to point at "**PROG**".

Press "**Select**" to start the irrigation program. The time page will be displayed showing the program running.

```
TIME      VAL 1 PRG 1
12:22
```

Manual Stop

Pressing "**Start/Stop**" at any time when a program, valve or pump is running will stop the program, valve or pump immediately.

7. A Couple of Short Cuts

Set All

When setting up an irrigation program, the '**Set All**' key is a quick method of setting a number of valves to the same time.

When the "**Enter Valve Time**" page is displayed, press the "**Set All**" key. The following page will be displayed.

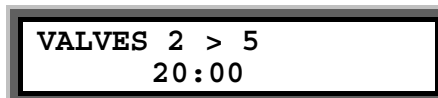

VALVES 2 > 5
20:00

Using the arrow forward key ">" and the keypad, the range of valves to be set to the same run time, and the run time itself, can be entered. In the example shown above, valves 2 through to 5 have all been set to run for 20 minutes each.

Pressing "**Set All**" again will return you to the program.

Manual Advance

When the irrigation program is running, press "**Manual Advance**" to move the program onto the next valve in the sequence.

This can be useful when testing your system.

8. Resetting the Clock

- Press ">" until the "**Time Page**" is shown.
- Now Press and hold down the "**0**" key for five seconds. A black flashing cursor will appear.
- Using number keys and ">" the correct time of day can be entered.
- When you have reset the time, press the ">" twice or wait **15** seconds. The black flashing cursor will disappear.
- The time has been reset.

9. Fault Messages

Overload

During the running of an irrigation program a current overload condition may occur. The most common reasons for a current overload condition are:-

- A short circuit on the solenoid valve wiring
- Too many valves running at the same time
- A faulty solenoid valve.

Should a current overload condition occur then the irrigation program will skip to the next valve to be run in the sequence.

Once the irrigation program has finished, the “Valve Fault” message will be displayed along with the number of the valve where the fault was detected. In the example below, the second valve in the irrigation program was faulty.

TIME	VALVE 02
12:11	O/L 1 FAULT

The controller will continue to run irrigation programs until four overload conditions are registered. The “Valve Fault” message will continue to be displayed after an irrigation program has run until the “Start/Stop” button is pressed.

If four overload conditions are registered then the running of all irrigation programs will cease. Pressing “Start/Stop” will reinitiate the running of irrigation programs again.

O/L1 means a semi short circuit. O/L2 means a direct short circuit.

Low Tank

“Low Tank” indicates that the water level in the storage tank is low.

The irrigation program will temporarily stop. Once the water tank has been filled, the irrigation program will start again.

Freeze

“Freeze” indicates that a sensor connected to the remote stop input has been activated.

Once the freeze condition has been removed from the input, the irrigation program will start again from the point at which it was temporarily halted.

Stop

“Stop” indicates that a sensor connected to the remote stop input has been activated. In this case, the irrigation program will not restart when the remote stop condition is removed.

10. Taking Care of Your Controller

Battery Back-Up.

Your controller has a battery to keep the clock running when there is no mains power. The battery will keep the clock running for 3-5 years.

To ensure the battery lasts for the life of the product avoid disconnecting mains power for months at a time. However, should the battery run flat, it can be replaced.

The battery is located inside the lid on the top right hand side. To replace the battery, disconnect mains supply and open the lid. The battery is simply slipped out of its holder and a new one inserted. The battery type is CR 2016.

Never - use sharp objects to press the buttons on your controller. Avoid pressing the buttons with your finger nails.

Always - ensure the lid screws are screwed down tightly to keep the inside of the controller dry and to reduce exposure to high humidity.

Leave Mains Power On Over the Winter - to keep the controller warm and prevent the inside of the casing becoming damp.

11. Fuses

The following fuses are fitted. **Never fit higher values. All Fuses are Slow Blow.**

AC Output Controllers

F1	Mains Input Fuse 630mA Input Connector)	(In Plastic Mains
F2	24 Volt Bulk Fuse 2.0A Board)	(Left of Bottom
F3	2 nd Pump Output and Permanent 24V output 630mA Board)	(Right of Bottom
F4	Electronics Fuse 250mA	(On board in lid)

DC Output Controllers

F1	Mains Input Fuse 630mA Input Connector)	(In Plastic Mains
F2	12Volt Bull fuse 250mA Board)	(Left of Bottom
F2A	24 Volt Valve Output Fuse 1.6A Board)	(Left of Bottom
F3	Permanent 24V output 630mA Board)	(Right of Bottom
F4	Electronics Fuse 250mA	(On board in lid)

MCI-4, MCI-8, MCI12, MCI-16, and MCI-96 declaration of conformity.

USA This product has been certified as an FCC **Class B** device.

Declaration of Conformity

We herewith declare that all products manufactured by the company below meet the requirements of EC directives.

Applied Standards Are:

EN 50081-1 EMC Generic Emission

EN 50082-2 EMC Generic Immunity

To comply the product must be permanently installed in accordance with the installation instructions provided and the electrical supply must be sinusoidal.

USA This product has been certified as an FCC **Class B** device

Heron Electric Co Ltd,

Unit G15 Rudford Industrial Estate, Arundel, England

12. Changing Configuration Options

This section describes the basic options you can set on your controller. There are just 15 basic options. If you need to use the more advanced features please refer to the 'Advanced Options' manual.

To access the configuration options press and hold down **"Manual Advance"** button for **10 seconds**. The following page will be displayed.

OPTION	1	2	3
	8	3	0

The arrow forward key ">" is used to position the cursor under the option you want to change. Use the keypad to enter the required number, as described below, to activate the option.

In the example above, Option's 1,2 and 3 have been set to 8, 3 and 0. When the required options have been set, press the arrow forward ">" or arrow backward key "<" repeatedly until the 'Time' page is shown.

IMPORTANT: Always fully test any new configuration after you have changed any options to check the controller functions as you require.

Note: You irrigation installer or dealer may have already set the configuration options to the required values for you.

The 15 basic options are listed below.

Option	Brief Description	Default Value
Option 1	Set number of valves.	4-96
Option 2	Set number of Daily automatic starts.	3
Option 3	Set number of Weekly automatic starts.	0
Option 4	The number of irrigation programs	1
Option 5	Set pump pressurisation time in minutes.	0
Option 6	Set pump pressurisation time in seconds.	2
Option 7	Rain sensor connected and number of historical rain days	0
Option 8	The Day of the week (1 = Monday, 2 = Tuesday)	1-7
Option 9	Controller does a permanent Stop instead of Freeze	0
Option 10	Display Low Tank instead of Freeze or Stop	0
Option 11	Use Percentage Up and Down	0
Option 12	Not used	0
Option 13	Use 'Disable Automatic Starts' facility	0
Option 14	Enable Serial Number Page (MCI-100S Only)	0
Option 15	DISPLAY ADVANCED OPTIONS (OPTIONS 16 TO 72)	0

Number of Valves (Option 1)

If you increase the number of valves on your controller you will need to change Option 1. For example if you have upgraded a 16 valve controller to a 32 valve controller, enter '32' under Option 1. There will be no change to the operation of the controller, just more valve pages will be displayed. (Values between 4 and 96 are allowed).

Number of Daily Automatic Starts (Option 2)

If you need to increase or decrease the number of Daily automatic starts change Option 2. Enter the required number under Option 2. There will be no change to the operation of the controller just more Daily automatic start pages will be displayed. (Values between 0 and 51 are allowed).

Number of Weekly Automatic Starts (Option 3)

If you need to increase or decrease the number of Weekly automatic starts change Option 3. Enter the required number under Option 3. Values between 0 and 32 are allowed.

When weekly programming is selected an additional page will be displayed for each automatic start. An example is shown below.



AUT 4
OFF MON AT 0:00

- To enable the automatic start move the cursor under 'OFF'. Now press the **Select** button to select the program.
- To set the day of the week move the cursor under **MON**. and press the **Select button** repeatedly to change the day of the week.
- Set the time move the cursor under the time and change it.



AUT 4
PRG1 TUE AT 12:00

In the example above Program 1 will start at 12:00 on Tuesday.

Number of Irrigation Programs (Option 4)

Set option 4 to the number of irrigation programs you need. A maximum of 16 irrigation programs are allowed. If this is option is not set the controller will use just one irrigation program.

Once you have set this option you can then modify and use more than one irrigation program. Modification of additional irrigation programs is exactly the same as modifying Irrigation Program 1. All you have to do is set the number of the program you want to edit.

Pump Pressurisation Time in Minutes (Option 5)

The pump pressurisation time (in minutes) can be set with Option 5. (Values between 0 and 99 minutes are allowed).

Pump Pressurisation Time in Seconds (Option 6)

The pump pressurisation time (in seconds) can be set with Option 6. (Values between 0 and 99 seconds are allowed).

Rain Sensor to Reduce Watering (7)

The Heron rain sensor allows the irrigation program to be reduced depending on the amount of rain that has fallen over the last few days. Two trip points can be set.

If you have a rain sensor, set Option 7 to the number of days you wish the rain sensor to work over. For example if you set Option '7' to 3 then rain that has fallen within the last 3 days will still be included in the rain fall measurement. The maximum value you can set option 7 to is 4.

Setting Option 7 to zero will disable the rain sensor.

Connecting the Rain Sensor

Connect the two terminals inside the rain sensor to Input 2 (across "I2" and "C2"). The terminals in the rain sensor are accessed by removing the bottom of the rain sensor.

Using the Rain Sensor

When option 7 is set, the rain page is displayed after the Automatic Start pages. Press ">" or "<" to view the page. The rain page is shown below.

RAIN	ADJ	50%	100%
2mm	TRIP	4mm	9mm

On the rain page you can set two trip points in mm of rain fall. When these trip points are met irrigation programs will run for either :

- 50% (half) of their normal time
- 0% of their normal time (i.e. not run).

To set a trip point move the cursor under the appropriate percentage (50%, or 0%) and enter a number . In the example above trip points have been set at 4 mm and 9 mm.

Testing the Rain Sensor

The rain sensor can be tested by pressing the spoon down inside the rain sensor . Pressing the spoon down every 10 seconds will increment the rain fall by 1 mm. If you press the spoon enough times so that a trip level is reached you will see a reduction in the irrigation watering programs.

Note:

- The rain sensor has no effect on a manual valve or manual program start
- One minute must elapse before the percentage reduction will be registered after the threshold is reached.

Setting the Day of the Week (Option 8)

The current day of the week for weekly automatic starts should not normally need changing. If you do need to change the day of the week set Option 8 to 1 for Monday, 2 for Tuesday, 3 for Wednesday etc.

Remote Stop Option (Option 9)

This controls whether irrigation programs should freeze or permanently stop when the remote stop input is activated.

Set option 9 to '0' to freeze irrigation programs. Irrigation programs will start again from the point at which they stopped when the remote stop condition is removed.

Set option 9 to '1' to stop irrigation programs. Irrigation programs will not automatically start again when the remote stop condition is removed.'

'Low Tank' Display (Option 10)

Option '10' changes the remote stop input message to 'Low Tank'. To display 'Low tank' instead of 'Freeze' or 'Stop', set option '10' to '1'. Default is '0'.

Percentage Up and Down (Option 11)

Percentage Up and Down allows all irrigation run times to be temporarily adjusted by a specified percentage (0%-250%). With Option 25 set to '1' the following page will be displayed after the Automatic Start pages.

If no increase or decrease is required, then the percentage value must be set to 100%.

<p>SET PROGS 1-16 50%</p>

In the example above irrigation programs will run for half their normal time.

IMPORTANT: Do not leave the percentage value at 0%. No irrigation will run.

Automatic Start disable (Option 13)

Option 13 allows all automatic starts to be disabled by pressing the **Select** key when on the Time page. When automatic starts are active the controller will display the following:-



TIME AUTOS ON
12:00

If the **Select** key is pressed the controller will then display the following and all automatic starts will be disabled until the **Select** key is pressed again.



TIME AUTOS OFF
12:00

Enable and Display Advanced Options (Option 15)

If you wish to use the 'Advanced Options' set Option 15 to 1. Advanced Options are Options 16 onwards.

With option 15 set at 0 you will not be able to access the Advanced Options. Furthermore, the controller will ignore the value of all Advanced Options if Option 15 is 0.

HERON ELECTRIC COMPANY LTD

Advanced Options Manual

MCI-4, MCI-8, MCI-12, MCI-16, and MCI-96

This manual refers to MCI Controllers using software version 49AXX and 49BXX

Doc Ref MCI4-96 49A & 49B Advanced

01 March 2004

Table of Contents

<i>1</i>	<i>Changing Configuration Options.....</i>	<i>2</i>
<i>2</i>	<i>Advanced Options.....</i>	<i>3</i>
<i>3</i>	<i>Pump Control</i>	<i>4</i>
<i>4</i>	<i>Irrigation Programs</i>	<i>5</i>
<i>5</i>	<i>Automatic Starts</i>	<i>8</i>
<i>6</i>	<i>Continual Cycling</i>	<i>9</i>
<i>7</i>	<i>Weaning and Chaining.....</i>	<i>11</i>
<i>8</i>	<i>Fertigation (Option 41).....</i>	<i>12</i>
<i>9</i>	<i>Installation Options.....</i>	<i>13</i>



1 Changing Configuration Options

This manual describes the advanced features of the controller. Advanced features are activated by changing the configuration options of your controller. To access the configuration options: press and hold down the **"Manual Advance" for 4 seconds**.

The advanced options are from Option 16 onwards. The basic Options (1-15) are listed here for completeness.

IMPORTANT: Always fully test any new configuration after you have changed any options to check the controller functions as you require.

Basic Options 1-15.

Option	Function - See Basic Manual for detailed description	Default Value	Allowed Values
1	Set number of valves.	4	4-96
2	Set number of Daily automatic starts.	3	0-30
3	Set number of Weekly automatic starts.	0	0-32
4	The number of irrigation programs	1	1-15
5	Set pump pressurisation time in minutes.	0	0-59
6	Set pump pressurisation time in seconds.	2	0-59
7	Rain sensor connected and number of historical rain days	0	0-4
8	The Day of the week (1 = Monday, 2 = Tuesday)	1-7	1-7
9	Controller does a permanent Stop instead of Freeze	0	0/1
10	Display Low Tank instead of Freeze or Stop	0	0/1
11	Use Percentage Up and Down	0	0/1
12	Spare	0	0
13	Use 'Disable Automatic Starts' facility	0	0/1
14	Spare	0	0
15	DISPLAY ADVANCED OPTIONS (OPTIONS 16 TO 81)	0	0/1

2 Advanced Options

Option	Function	Default Value	Allowed Values	Section
16	Allocate input 1 (I1) to a specific program	1	1-15	4
17	<i>MCI100S option</i>	0	0	N/A
18	<i>Cycling uses remote start</i>	0	0	N/A
19	Maximum number of automatic started programs to run together	0	0-4	4
20	Maximum number of cycling programs to run together	0	0- 4	6
21	Allow only one program to run whether 'normal' or 'cycling'	1	0/1	6
22	<i>Multi-Interface Board uses Alarm op as 4th op</i>	0	0/1	*
24	Wean facility	0	0/1	7
25	Chain Programs 1,2,3 and 4	0	0/1	7
26	<i>Single Analog Interface Board Fitted</i>	0	0/1	*
27	<i>Remote Input interface Board Fitted</i>	0	0/1	*
28	<i>Multi-Interface Board Fitted</i>	0	0/1	*
29	Cycling programs take priority over automatic started programs	0	0/1	6
30	Program 1 will take priority	0	0/1	4
31	Program 1 Options	0	0/127	4
32	Program 2 Options	0	0/127	4
33	Program 3 Options	0	0/127	4
34	Program 4 Options	0	0/127	4
35	Program 5 Options	0	0/127	4
36	Program 6 Options	0	0/127	4
37	Program 7 Options	0	0/127	4
38	Program 8 Options	0	0/127	4
39	Irrigation by Volume instead of Time (available June)	0	0/1	10
40	Manually start valves in parallel	0	0/1	4
41	Fertigation	0	0/1	9
44-53	<i>MCI-100S options</i>	0	0	N/A
55	Controller address – PC option	1	0-5	*
56	Baud Rate- PC Option	2	0- 2	*
57	Keypad security	0	0- 99	11
58	Delay between valves in Seconds	0	0-59	4
59	Allocate programs to start Pump 1	15	0-15	3
60	Specify number of back flush valves	0	0– 92	8
65	Number of Log Days – PC option	0	0-32	*
66	Number of Log Days Confirmation- PC Option	0	0-32	*
68	Delay Between Valves (Option 58) in Minutes	0	0/1	4
70	Number of Automatic Start programs to back-up	0	0-16	5
71	Number of Continual Cycling programs to back-up	0	0-16	6
72	Volume Meter Type	0	0-127	*
73	Volume Meter Units	0	0-127	*
74	Volume Meter Timing window	0	0-127	*
75	Volume Meter Scaler	0	0-127	*
76	Volume Meter Hold Off for Flow rate Alarm	0	0-127	*
77	Max Percentage error in flow rate	0	0-100	*
79	<i>Number of MPD Dosing Controllers Connected</i>	0	0-1	*
80	<i>Logging rate of Flow and EC and pH values</i>	0	0-99	*
81	<i>Logging rate of Analogue Values</i>	0	0-99	*
82	GSM module connected #	0	0/1	*
83	Display GSM display GSM data #	0	0/1	*
84	Send text message on every fault #	0	0/1	*
85	Inputs 6 and 7 are monitor inputs only #	0	0/1	*
86	Site number #	0	0-99	*
87	Max number of faults before system shut down #	0	1-99	*

* see separate manual

#49B software only

3 Pump Control

Allocate Programs to Start Pump 1 (Option 59)

This option controls which irrigation programs start Pump 1.

If option 59 is set to '1' **only program 1** will start Pump 1.

If it is set to '2', **programs 1 and 2** will start Pump 1 etc.

Values between '0' to '15' can be used. If option 59 is set to '15', all programs will start Pump 1. Default is '15'.

4 Irrigation Programs

Maximum Number of Automatically Started Programs to Run Together (Option 19)

This specifies the maximum number of automatically started irrigation programs that can run at the same time. If this option is set to '0', only one irrigation program can run at any time. Setting this option to 2 will allow 2 irrigation programs to run at the same time.

Note: A maximum of 4 irrigation programs can run at any time. This includes automatically started AND continually cycling programs. See option 20 below.

Allocate Remote Start input to a Program (Option 16)

The Remote Start Input can be assigned to initiate any irrigation program. Enter the number of the irrigation program you want it to initiate. If this option is not set, the Remote Start Input will trigger irrigation program 1 by default.

Program 1 will Take Priority (Option 30)

This allows program 1 to take priority over any other automatically started irrigation programs. If you need his facility set Option 30 to '1'. Default is '0'.

With Option 30 set, if a program is running, and program 1 wishes to start, it will cut-in and run. The halted irrigation program will continue from where it was stopped, once program 1 has completed.

Note: You must set option 19 and 20 to 1 and set option 21 to 0.

Delay Between Valves (Option 58)

A delay between the operation of the valves within an irrigation program can be introduced using this option. The delay can be set from 1 to 255 seconds. Enter the number of seconds delay required. The delay will apply to all irrigation programs. If you require the delay in minutes use Option 68.

Delay Between Valves In Minutes (Option 68)

Option 68 sets the delay between valves in minutes rather than seconds. With this option set the pump will switch off during the delay period.

Allow Programs to be manually Started in Parallel (Option 40)

With Option 40 set programs can be manually started in parallel. Operation of the controller is exactly the same except that pressing **Start/Stop** will **always** show the following page.

START	>PUMP
VALVE	
	PROG STOPALL

To manually stop the controller you must press **Start/Stop** to display the page above and then press '>' to move the cursor to 'STOPALL' and the press **Select**.

To allow programs to run in parallel you must also set one or both of the parallel program Options (Option 19 or 20).

Program Configuration Options: Option 31 to 38

Program configuration options allow individual programs to be customised. Option 31 relates to program 1, Option 32 to program 2 etc. Programs 1 to 8 can be individually customised.

The following 6 features can be set for each program.

	Value	Description of facility
Program has Continual cycling facility (For version 49A controllers you must use lowest number programs ie you cannot cycle Program 2 without assigning cycling to Program 1.)	+1	See section 5
Program Valve time in Hours and Minutes	+2	Sets time in hours and minutes instead of minutes and seconds
Program ignores Percentage reduction	+4	Ignores percentage reduction whether set manually or by rain sensor (always runs at 100%)
Program ignores the Freeze input	+8	Program ignores the freeze or Stop inputs.
Program can be started via Analogue input on MF interface	+16	See MF interface manual
Program can be started via light	+32	See Light sensor manual (only applies to programs 1,2,3 and 4)
Parallel Valves	+64	

To include a feature add the value of the facility to the Option .

For example suppose you require continual Cycling on Program 1 and Program 1 to Ignore Freeze input. For program 1 we must change Option 31. Now Continual Cycling has a value 1 and 'Ignore Freeze Input' has a value 8. The required value for Option 31 is **1+8=9**.

Program Ignores Percentage Reduction (+4)

This facility allows a program to ignore any percentage reduction that is set. For example you may not want indoor irrigation to be affected by the rain sensor percentage reduction. As described above add 4 to the appropriate Program Option number.

Program Ignores Freeze Input (+8)

This facility allows a program to ignore the Freeze Input. For example you may have two different irrigation systems one which uses a water storage tank and one that uses mains water. This facility can prevent the mains water irrigation from being suspended when the water storage tank runs low. As described above add 8 to the appropriate Program Option number.

Program Runs Valves in Parallel (+64)

This facility allows the program to run valves in parallel.

For programs 1 to 6, **two** valves within the program will run in parallel.

For programs 7 and 8, **four** valves within the program will run in parallel.

5 Automatic Starts

The controller allows daily and weekly automatic starts to be set. You can specify the number of each type of automatic starts you wish to use. You can specify up to 30 **daily** automatic starts and up to 32 **weekly** automatic starts, see 'Basic Manual'.

Number Automatically Started Programs to Back-Up (Option 70)

If an 'Automatically Started' program cannot run because another program is running the controller can remember that a program tried to start. The controller will run the program when the other program(s) have finished. Option 70 controls the number of automatic starts that the controller will remember. Values between 0 and 16 are allowed.

Set Option 70 to 0 if you do not want any Automatic Starts remembered. Set Option 70 to '1' for one start to be remembered, set to 2 for 2 starts etc. Default is 0.

6 Continual Cycling

The continual cycling facility allows irrigation programs to continuously cycle. Programs continually cycle between a specified start and stop time, with a programmable delay between cycles. This is normally used for misting or propagation applications.

To set a program to continually cycle add **+1** to the appropriate Program Option. Option 31 is for Program 1 and Option 32 is program 2 etc. See Section 4 for more details.

Setting Up Continual Cycling

An extra page will be displayed after the Automatic Start Pages, as shown below, for each continually cycling program. This page allows you to:

- Specify the start and stop times for the continual cycling period
- Set the delay period (in hours and minutes) between each cycle
- Disable / Enable the continual cycling program.

When a program has continual cycling specified the following page is displayed. Press **"Select"** to enter the start and stop times for continual cycling and the delay period between cycles.

```
P1 CYCLE NEVER
WAIT 0:00
```

In the example below, program 1 has been set to continually cycle from 6:00 hours to 21:30 hours, with a 20 minute delay between each cycle.

```
P1                CYCLE
6:00>21:30
WAIT 00:20        NEXT
13:30
```

The time that the next cycle will begin is automatically calculated and displayed. In the example above, the next continual cycle of program 1 will begin at 13:30 hours.

Disabling Continual Cycling

You can disable the continual cycling program by pressing the **"Select"** button when the continual cycling page is displayed.

```
P1 CYCLE NEVER
WAIT 0:00
```

To re-enable continual cycling press the **"Select"** button again. The start times will be redisplayed.

```
P1                CYCLE
6:00>21:30
WAIT 00:20        NEXT
13:30
```

Other Options You May Want to Set

Max Number of Continual Cycling Programs to Back-Up (Option 71)

If a 'Continual Cycling' program cannot run because another program is running the controller can remember that a program tried to start. The controller will run the program when the other program(s) have finished. Option 71 controls the number of cycling starts that the controller will remember. Values between 0 and 16 are allowed.

Set Option 71 to 0 if you do not want any cycling starts remembered. Set Option 71 to '1' for one start to be remembered, set to 2 for 2 starts etc. Default is 0.

Maximum Number of Cycling Programs to Run Together (Option 20)

A maximum of 4 continual cycling programs can run together. Set this option to the number of continual cycling programs you want to run together ('1' to '4'). Default is '0'.

Allow Only One Program to Run whether 'Normal' or 'Cycling' (Option 21)

If option 21 is set to '1', only one irrigation program will ever run at any time. Option 21 overrides options 19 and 20 i.e. specifying how many automatically started and continual cycling programs can run at the same time. Default is '1'.

Note: If you want either automatically started or continually cycling irrigation programs to run at the same time, then you **must** set option 21 to '0'.

Cycling Programs to take Priority Over Auto Start Programs (Option 29)

This option allows any of the continual cycling programs to take priority over any automatically started irrigation program.

With this option set, if an automatically started irrigation program is running, the continual cycling program will cut-in and run. The halted automatically started irrigation program will then continue from where it was stopped, once the cycling program has completed.

If you want this facility set option 29 to '1'. Default is '0'.

Note: You must set option 19 and 20 to 1 and set option 21 to 0.

7 Weaning and Chaining

Setting Weaning Programs (Option 24)

The wean facility allows Programs 2,3 and 4 to be operated at less frequent intervals than Program 1. For example Program 2, will start half as many times as Program 1, see table below.

Programs 2,3 and 4 are automatically triggered after Program 1 finishes.

Irrigation Initiated	Irrigation Programs Run			
	Prog 1	Prog 2	Prog 3	Prog 4
First Time	X			
Second Time	X	X		
Third Time	X		X	
Fourth Time	X	X		X
Fifth Time	X			
Sixth Time	X	X	X	
Seventh Time	X			
Eighth Time	X	X		X
Ninth Time	X		X	

That is:

Program 2 will start every **second time** program 1 starts

Program 3 will start every **third time** program 1 starts

Program 4 will start every **fourth time** program 1 starts.

To activate the wean facility the following options must be set:

Chaining Programs (Option 25)

The chain facility allows Programs 1,2,3 and 4 to be chained together. With the option set when ever Program 1 finishes, Programs 2 will start and so on.

8 Fertigation (Option 41)

Option 41 should be set to '1' if a fertigation operation is required. Default is '0'. Fertigation allows fresh water to be irrigated before and after the application of fertiliser.

Fertigation will control up to 32 irrigation valves and one fertiliser valve. The 2nd pump start output is automatically assigned by the controller to operate the fertiliser valve. The 2nd pump start output is across C1 and 03.

When the fertigation option is activated, each valve time on the Irrigation Program Set Up page is divided up into three time periods, period 'a', 'b' and 'c', as illustrated below.

VALVE	1a	1b
1c	05:00	10:00
	05:00	

The fertiliser valve will be opened when ever the 'b' time period is run. The fertiliser valve will be closed when ever the 'a' and 'c' time periods are run, and fresh water only will be irrigated, see below.

Step 1	Switch valve 1 on for 5 minutes and irrigate fresh water only.
Step 2	Leave valve 1 on and open the fertiliser valve for 10 minutes to introduce fertiliser into the irrigation line.
Step 3	Close the fertiliser valve and leave valve 1 on for another 5 minutes to irrigate fresh water only.
Step 4	Switch valve 1 off. Valve 1 has remained open for a total of 20 minutes.

Note: If you are using delay between valves (option 11) with fertigation you must set a time under 'a' for each valve you are using. It only needs to be a short time e.g. 5 seconds.

Limitations To use The fertigation option disables the manual starting of a valve and disables the use of Set All.

9 Installation Options

Max Faults (Option 87)

Option 87 is the maximum number of faults that are allowed before the controller will switch off all irrigation programs.

Keypad Security (Option 57)

If you require a security code to be entered before the controller can be used , then set option 57.

Set option 57 to any number from '01' to '99'. This number will become the third and fourth digits of the security code. The first and second digits of the security code will be '57'.

For example, if option 57 has been set to '15', then the security code "5715" must be entered when ever the controller is operated.

The user must enter the security code if the keypad is not used for three minutes