

HERON ELECTRIC COMPANY LTD

Basic User and Installation Manual

MCI-4, MCI-8, MCI-12, MCI-16, and MCI-96

Doc ref.MCI4-96 4551 BASIC

1 About This Controller

Congratulations, you are now the owner of a Heron MCI irrigation controller.

Your controller will operate 24volt AC* solenoid valves. The controller will run the valves for the length of time, and in the order you specify. This sequence of running solenoid valves is known as an **irrigation program**.

Irrigation programs can be started automatically at pre-set start times. Alternatively, an irrigation program, a single solenoid valve or the pump, can be started manually at any time.

2 Wiring Up

Mounting the Controller

The controller should be mounted on a wall using four screws, one screw through each of the corner lid bolt holes.

Wiring Up Your Controller

The MCI-96, MCI-16, MCI-12 and all DC controllers should be wired up as shown in Fig 1.

The MCI-8 and MCI-4 controllers should be wired up as shown in Fig 2 below .

For an MCI-96 with more than 16 valves, wire up the output expansion box to the connector marked "EX".

Connecting Mains Supply

IMPORTANT: Ensure the mains supply voltage is the same as the voltage of the controller. The controller voltage is displayed inside the controller.

As with any equipment used in damp conditions, the mains supply should be fused with a Residual Current Circuit Breaker (3 amp fuse). Connect the mains supply to the three terminals as shown in Figs 1 and 2, L to Live, N to Neutral E to Earth.

Do not wire other equipment in parallel with the controller supply.

Connecting Solenoid Valves

Connect each solenoid valve to the appropriate output as shown in Figs 1 and 2. The common wire from each solenoid valve should be connected to the "C1" terminal. Valves can be connected in parallel provided the maximum valve output current does NOT exceed the output current rating of the controller.

Connecting Pumps

Two pump control outputs are available, namely "Pump-1" and "Pump-2".

The "Pump-1" output is across the "O1", "C1" terminals. Connect a suitable 24V relay across these terminals to control the pump.

The "Pump-2" output is across "O3" and "C1". Connect a suitable 24V relay across these terminals to control the second pump.

The second pump start output, "Pump-2", operates with irrigation programs 7 to 16.

Fig 1 Wiring Diagram for MCI-4 and MCI-8

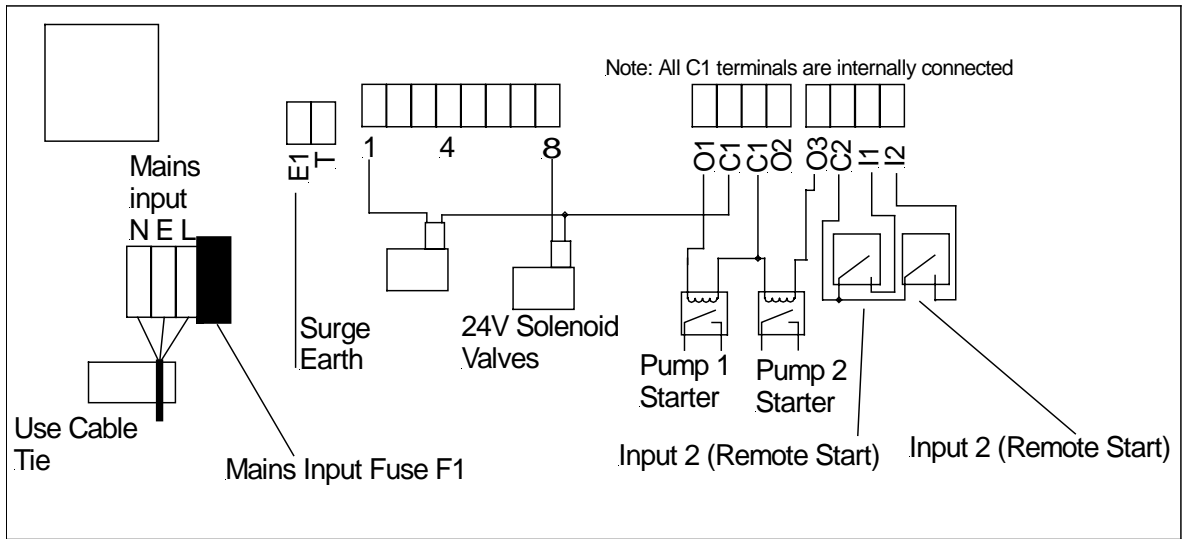
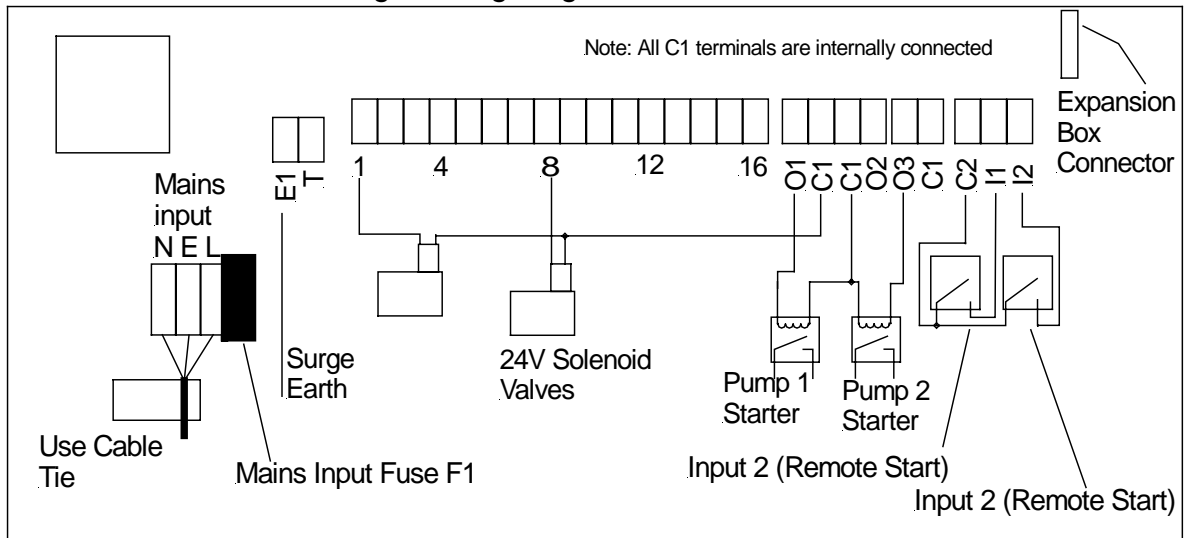

Fig 2 Wiring Diagram for MCI-12 MCI-16 and MCI-96



3 More Inputs and Outputs

Remote Start

The remote start input is across "I2" and "C2". Joining these terminals will start program 1. The terminals have to be connected for only a short period, 1 second, to activate the program. If the contacts are left shorted program 1 will continually cycle.

Remote Stop / Low Water Cut Out

The remote stop input is across "I1" and "C2". Joining these inputs halts the irrigation programs. The programs will continue once the short is removed.

This input may be connected to a float switch in the water reservoir so that the irrigation sequence is halted if the water level is low.

24V Output

A 24V supply is permanently available across "O2" and C1".

When the you switch on the power the **Time Page** is displayed as shown below.

Now **Pressing** '>' shows the first valve Page of Program 1

TIME	VALVES OFF
11	

Now **Pressing** '>' shows the next valve page

VALVE 1	2	3
00:00	00:00	00:00

Now **Pressing** '>' shows the next valve page

VALVE 4	5	6
00:00	00:00	00:00

Now **Pressing** '>' shows the Automatic Start Page

VALVE 7	8
00:00	00:00

AUTO OFF	OFF	OFF
1 0:00	0:00	0:00

Now pressing '>' will return you to the Time Page again.

4 Getting to know your controller

5 Your First Irrigation Program

By means of an example this section describes how to set an irrigation program and set an automatic start.

Setting the Irrigation Program

Press '>' until the valve page is displayed as shown below.

With the cursor flashing under "VALVE 1", press "1" and "0" to enter 10 minutes as shown below.

VALVE 1	2	3
10:00	0:00	0:00

Press the ">" twice to move the cursor under VALVE 2 and press "5" as shown below.

VALVE 1	2	3
10:00	5:00	0:00

Setting the Automatic Start Times - The Steps

Press the arrow forward key ">" until the "Automatic Start Time" page is displayed.

AUTO OFF	OFF	OFF
1 0:00	0:00	0:00

With the cursor flashing on the first zero, press the "6" on the keypad to enter a 6:00 am start time.

AUTO OFF	OFF	OFF
1 6:00	0:00	0:00

You must now activate the start time by pressing the "Select" button whilst the flashing cursor is still positioned on the start time. You will see the display above the start time change from "OFF" to "PRG1".

AUTO PRG1	OFF	OFF
1 6:00	0:00	0:00

"PRG1" indicates that a start time has been activated as shown above.

To enter a second automatic start time, press the arrow forward key ">" until it is positioned on the first zero of the second start.

Press the arrow forward key ">" to return to the "Time Page".

Congratulations....You have now set up your first irrigation program.

6 Starting and Stopping

To manually start the **pump, a valve or an irrigation program** press 'Start/Stop' and the following page will be displayed.

```
START >PUMP VALVE
          PROG
```

Pump Start

With the flashing arrow pointing at "**PUMP**" press "**Select**" to start Pump 1. The display below will be shown.

```
TIME      PUMP ON
12:30
```

Valve Start

Press the arrow forward key ">" to position the flashing arrow to point at "**VALVE**".

Press "**Select**" and the page below is shown.

```
START VALVE 5 TIME 2
```

Enter the number of the valve to be started.

Press the ">" and then enter the number of minutes the valve is to run.

In the example above valve 5 has been set to run for 2 minutes.

Now press "**Select**" to start this valve. The "**Time Page**" will be displayed as shown below.

```
TIME      VALVE 5 1:58
12:00
```

Program Start

To start an irrigation program press the arrow forward key ">" to move the flashing arrow to point at "**PROG**".

Press "**Select**" to start the irrigation program. The time page will be displayed showing the program running.

```
TIME      VAL 1 PRG 1
12:22
```

Manual Stop

Pressing "**Start/Stop**" at any time when a program, valve or pump is running will stop the program, valve or pump immediately.

7 A Couple of Short Cuts

Set All

When setting up an irrigation program, the '**Set All**' key is a quick method of setting a number of valves to the same time.

When the "**Enter Valve Time**" page is displayed, press the "**Set All**" key. The following page will be displayed.

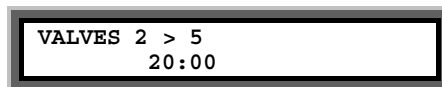

```
VALVES 2 > 5
20:00
```

Using the arrow forward key ">" and the keypad, the range of valves to be set to the same run time, and the run time itself, can be entered. In the example shown above, valves 2 through to 5 have all been set to run for 20 minutes each.

Pressing "**Set All**" again will return you to the program.

Manual Advance

When the irrigation program is running, press "**Manual Advance**" to move the program onto the next valve in the sequence.

This can be useful when testing your system.

8 Resetting the Clock

- Press ">" until the "Time Page" is shown.
- Now Press and hold down the "Select" key for five seconds. A black flashing cursor will appear.
- Using number keys and ">" the correct time of day can be entered.
- When you have reset the time, press the "Select" key again. The black flashing cursor will disappear.
- The time has been reset.

9 Fault Messages

Overload

During the running of an irrigation program a current overload condition may occur. The most common reasons for a current overload condition are:-

- A short circuit on the solenoid valve wiring
- Too many valves running at the same time
- A faulty solenoid valve.

Should a current overload condition occur then the irrigation program will skip to the next valve to be run in the sequence.

Once the irrigation program has finished, the "Valve Fault" message will be displayed along with the number of the valve where the fault was detected. In the example below, the second valve in the irrigation program was faulty.

TIME	VALVE 02
12:11	O/L 1 FAULT

The controller will continue to run irrigation programs until four overload conditions are registered. The "Valve Fault" message will continue to be displayed after an irrigation program has run until the "Start/Stop" button is pressed.

If four overload conditions are registered then the running of all irrigation programs will cease. Pressing "Start/Stop" will reinitiate the running of irrigation programs again.

O/L 1 means a direct short. O/L2 means a semie short.

Low Tank

"Low Tank" indicates that the water level in the storage tank is low.

The irrigation program will temporarily stop. Once the water tank has been filled, the irrigation program will start again.

Freeze

"Freeze" indicates that a sensor connected to the remote stop input has been activated.

Once the freeze condition has been removed from the input, the irrigation program will start again from the point at which it was temporarily halted.

Stop

"Stop" indicates that a sensor connected to the remote stop input has been activated. In this case, the irrigation program will not restart when the remote stop condition is removed.

10 Taking Care of Your Controller

Battery Back-Up.

Your controller has a battery to keep the clock running when there is no mains power. The battery will keep the clock running for 3-5 years.

To ensure the battery lasts for the life of the product avoid disconnecting mains power for months at a time. However, should the battery run flat, it can be replaced.

The battery is located inside the lid on the top right hand side. To replace the battery, disconnect mains supply and open the lid. The battery is simply slipped out of its holder and a new one inserted. The battery type is CR 2016.

Never - use sharp objects to press the buttons on your controller. Avoid pressing the buttons with your finger nails.

Always - ensure the lid screws are screwed down tightly to keep the inside of the controller dry and to reduce exposure to high humidity.

Leave Mains Power On Over the Winter - to keep the controller warm and prevent the inside of the casing becoming damp.

11 Fuses

The following fuses are fitted. **Never fit higher values. All Fuses are Slow Blow.**

AC Output Controllers

F1	Mains Input Fuse 630mA Input Connector)	(In Plastic Mains
F2	24 Volt Bulk Fuse 2.0A Board)	(Left of Bottom
F3	2 nd Pump Output and Permanent 24V output 630mA Board)	(Right of Bottom
F4	Electronics Fuse 250mA	(On board in lid)

HERON ELECTRIC COMPANY LTD

Advanced Options Manual

MCI-4, MCI-8, MCI-12, MCI-16, and MCI-96

This manual refers to MCI Controllers using software version 4551.

Doc Ref MCI4-96 4551 ADVANCED

Thursday, 07 December 2000

Table of Contents

1	Changing Configuration Options.....	2
2	Pump Control	4
3	Irrigation Programs.....	5
4	Automatic Starts	7
5	Water Budget.....	10
6	Continual Cycling (Option 18).....	12
7	Wean Facility (Option 24).....	14
8	Back Flushing.....	15
9	Fertigation (Option 36).....	18
10	Irrigation by Volume	19
11	Installation Options	20

12 Changing Configuration Options

This manual describes the advanced features of the controller. Advanced features are activated by changing the configuration options of your controller. How to change a configuration option is described below.

To access the configuration options: press and hold down the **"Manual Advance"** for **10 seconds**.

IMPORTANT: To use Advanced Options, Option 15 must be set to 1.

Option	Function	Default Value
1	Set number of valves.	4-96
2	Set number of Daily automatic starts.	3
3	Set number of Weekly automatic starts.	0
4	The number of irrigation programs	1
5	Set pump pressurisation time in minutes.	0
6	Set pump pressurisation time in seconds.	2
7	Allocate programs to start pump 1	16
8	Allocate 'I1' input to a specific program	1
9	Specify number of back flush valves	0
10	Back flush delay between valves	0
11	Delay between valves	0
12	The Day of the week (1 = Monday, 2 = Tuesday)	1-7
16	Use variable period automatic starts	0
17	Valve times in Hours and Minutes	0
18	Continual Cycling programs	0
19	Battery fitted (coin cell)	1
20	Advance to next valve if low current	0
22	Irrigate on Volume	0
24	Use wean facility	0
25	Use Percentage Up and Down	0
26	Run Programs in Parallel	0
27	Controller does a permanent Stop instead of Freeze	0
28	Back flush priority	0
29	Allow Program 1 to take priority	0
31	No pump program 1	0
33	Display 2 nd time page	0
34	Continual Cycling of 4 Irrigation programs	0
35	Percentage adjust on programs 7-16 only	0
36	Fertigation facility	0
37	Rain sensor connected and number of historical rain days	0
39	Cycling uses 'I2' input	0
40	Back flush PD and period	0
41	Back flush PD only	0
42	Use 'Disable Automatic Starts' facility	0
43	Display Low Tank instead of Freeze or Stop	0

13 Pump Control

Pump Pressurisation Time in Minutes (Option 5)

The pump pressurisation time (in minutes) can be set with Option 5. (Values between 0 and 99 minutes are allowed).

Pump Pressurisation Time in Seconds (Option 6)

The pump pressurisation time (in seconds) can be set with Option 6. (Values between 0 and 99 seconds are allowed).

Allocate Programs to Start Pump 1 (Option7)

This option controls which irrigation programs start Pump 1.

If option 7 is set to '1' **only program 1** will start Pump 1.

If it is set to '2', **programs 1 and 2** will start Pump 1 etc.

Values between '1' to '16' can be used. If option 7 is set to '16', all programs will start Pump 1. Default is '16'.

No Pump Program 1 (Option 31)

Option 31 prevents Pump 1 being started from program 1. Set option 31 to '1' if Pump 1 is not required to start with program 1. Default is '0'.

14 Irrigation Programs

Number of Valves (Option 1)

If you increase the number of valves on your controller you will need to change Option 1. For example if you have upgraded a 16 valve controller to a 32 valve controller, enter '32' under Option 1. There will be no change to the operation of the controller, just more valve pages will be displayed. (Values between 4 and 96 are allowed).

Number of Irrigation Programs (Option 4)

Set option 4 to the number of irrigation programs you need. A maximum of 16 irrigation programs are allowed. If this option is not set the controller will use just one irrigation program.

Once you have set this option you can then modify and use more than one irrigation program. Modification of additional irrigation programs is exactly the same as modifying Irrigation Program 1. All you have to do is set the number of the program you want to edit.

Display Second Run Time page (Option 33)

If 3 or 4 irrigation programs are running at the same, this option will allow you to view a second time page for the third and fourth programs. By setting option 33 to '1' the second run time page will be displayed. Default is '0'.

Allocate Remote Start input to a Program (Option 8)

The Remote Start Input can be assigned to initiate any irrigation program. Enter the number of the irrigation program you want it to initiate. If this option is not set, the Remote Start Input will trigger irrigation program 1 by default.

Program 1 will Take Priority (Option 29)

This allows program 1 to take priority over any other automatically started irrigation programs. If you need his facility set Option 29 to '1'. Default is '0'.

With Option 29 set, if a program is running, and program 1 wishes to start, it will cut-in and run. The halted irrigation program will continue from where it was stopped, once program 1 has completed.

Note: If option 29 has been set then any the continually cycling program will have priority running over irrigation program 1.

Delay Between Valves (Option 11)

A delay between the operation of the valves within an irrigation program can be introduced using this option. The delay can be set from 1 to 99 seconds. Enter the number of seconds delay required. The delay will apply to all irrigation programs.

Rain Sensor and Manual Percentage to Reduce Watering for Programs 7-16 (Option 35)

The watering times of valves within programs can be reduced by either the connection of a rain sensor or by entering a manual watering reduction percentage. If option 35 is set, these two methods of reducing watering times, is limited to irrigation programs 7 to 16 only.

Set option 35 to '1' to activate this option. Default is 0.

Hours and Minutes (Option 17)

For program time in hours and minutes set Option 17 to '1'.



15 Automatic Starts

The controller allows daily and weekly automatic starts to be set. You can specify the number of each type of automatic starts you wish to use. You can specify up to **51 daily** automatic starts and up to **48 weekly** automatic starts'.

Number of Daily Automatic Starts (Option 2)

If you need to increase or decrease the number of Daily automatic starts change Option 2. Enter the required number under Option 2. There will be no change to the operation of the controller just more Daily automatic start pages will be displayed. (Values between 0 and 51 are allowed).

Number of Weekly Automatic Starts (Option 3)

If you need to increase or decrease the number of Weekly automatic starts change Option 3. Enter the required number under Option 3. Values between 0 and 48 are allowed.

When weekly programming is selected an additional page will be displayed for each automatic start. An example is shown below.

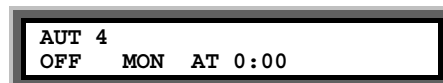

AUT 4
OFF MON AT 0:00

- To enable the automatic start move the cursor under 'OFF'. Now press the **Select** button to select the program.
- To set the day of the week move the cursor under **MON**. and press the **Select button** repeatedly to change the day of the week.
- Set the time move the cursor under the time and change it.

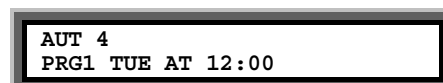

AUT 4
PRG1 TUE AT 12:00

In the example above Program 1 will start at 12:00 on Tuesday.

You also have the option to specify variable period automatic starts instead of weekly automatic starts. For example, you can specify that one program starts every three days and another program starts every four days.

Setting the Day of the Week (Option 12)

The current day of the week for weekly automatic starts should not normally need changing. If you do need to change the day of the week set Option 12 to 1 for Monday, 2 for Tuesday, 3 for Wednesday etc.

Variable Period Automatic Starts (Option 16)

Weekly automatic starts only allow programs to be started on specific days.. If you need programs to start at differing intervals set option 16 to '1' to allow 'variable period' automatic starts. The maximum interval for a variable period automatic start is 9 days.

When option 16 is set to '1' the Weekly Automatic Start pages change to the following format.

```
AUTO4          TODAY=1ST
OFF  1ST DAY AT  0:00
```

Setting a variable automatic start is very similar to a weekly automatic start except that you must specify **what day** it is today for **each automatic start**. This is described in the following example.

Example: Program 1 to start every 2 days at 12:00 starting tomorrow.

Program 2 to start every 3rd day at 09:00 starting today.

For program 1 set a variable automatic start page, using the cursor back, cursor forward and the number keys, as shown below.

```
AUTO4          TODAY=1ST
PRG1  2ND DAY AT  12:00
```

On day 1, the 'TODAY' equals count will be set as "1st". Program 1 will not start.

On day 2, the 'TODAY' equals count will automatically change to "2nd". Program 1 will run.

On day 3, the 'TODAY' equals count will automatically change to "1st". Program 1 will not start.

On day 4, the 'TODAY' equals count will automatically change to "2nd". Program 1 will run...etc.

For program 2 press the '>' button to move to the next variable automatic start and change the page to the one shown below.

```
AUTO5          TODAY=1st
PRG2 3rd Day AT  09:00
```

Program 2 is set to start on the 3rd day. The problem is that the 'TODAY' equals count will equal the 3rd day in two days time. We want Program 2 to start today and not in 2 days time. To make this happen we must manually set the 'TODAY' equals count to the 3rd day by using the '>' button to position the cursor on the 1st and pressing the '3' button.

```
AUTO6          TODAY=3rd
PRG2 3rd Day AT  09:00
```

On day 1, the 'TODAY' equals count will be set as "3rd". Program 2 will run.

On day 2, the 'TODAY' equals count will automatically change to "1st". Program 2 will not start etc.

On day 3, the 'TODAY' equals count will automatically change to "2nd". Program 2 will not start.

On day 4, the 'TODAY' equals count will automatically change to "3rd". Program 2 will run.

On day 5, the 'TODAY' equals count will automatically change to "1st". Program 2 will not start etc

16 Water Budget

Percentage Up and Down (Option 25)

Percentage Up and Down allows all irrigation run times to be temporarily adjusted by a specified percentage (0%-250%). With Option 25 set to '1' the following page will be displayed after the Automatic Start pages.

If no increase or decrease is required, then the percentage value must be set to 100%.

SET PROGS 1-16
50%

In the example above irrigation programs will run for half their normal time.

IMPORTANT: Do not leave the percentage value at 0%. No irrigation will run.

Rain Sensor to Reduce Watering (37)

The Heron rain sensor allows the irrigation program to be reduced depending on the amount of rain that has fallen over the last day. Two trip points can be set.

Setting Option 37 to zero will disable the rain sensor.

Connecting the Rain Sensor

Connect the two terminals inside the rain sensor to Input 2 (across "I2" and "C2"). The terminals in the rain sensor are accessed by removing the bottom of the rain sensor.

Using the Rain Sensor

When option 37 is set, the rain page is displayed after the Automatic Start pages. Press ">" or "<" to view the page. The rain page is shown below.

RAIN	ADJ	50%	100%
2mm	TRIP	4	9

On the rain page you can set two trip points in mm of rain fall. When these trip points are met irrigation programs will run for either :

- 50% (half) of their normal time
- 0% of their normal time (i.e. not run).

To set a trip point move the cursor under the appropriate percentage (50%, or 0%) and enter a number . In the example above trip points have been set at 4 mm and 9 mm.

Testing the Rain Sensor

The rain sensor can be tested by pressing the spoon down inside the rain sensor . Pressing the spoon down every 10 seconds will increment the rain fall by 1 mm. If you press the spoon enough times so that a trip level is reached you will see a reduction in the irrigation watering programs.

Note:

- The rain sensor has no effect on a manual valve or manual program start
- One minute must elapse before the percentage reduction will be registered after the threshold is reached.

Automatic Start disable (Option 42)

Option 42 allows all automatic starts to be disabled by pressing the **Select** key when on the Time page. When automatic starts are active the controller will display the following:-



If the **Select** key is pressed the controller will then display the following and all automatic starts will be disabled until the **Select** key is pressed again.

17 Continual Cycling (Option 18)

This option allows irrigation program 1 to be continuously cycled with a programmable delay at the end of the program. This is normally used for misting/propagation applications.

Set Option 18 to '1' for program 1 continual cycling. Default is '0'. The time of day through which continuous cycling is active can be specified. For example, continual cycling can be disabled at night.

Note: Option 34 will allow irrigation programs 1,2,3, and 4 to be continually cycled.

Setting Up Continual Cycling

With option 18 set to '1', an extra page will be displayed after the Automatic Start Pages, as shown below. With option 34 set to '1', four of these extra pages will be displayed, one for each continual cycling program.

These pages allow you to:-

- specify the start and stop times throughout the day for the continual cycling period
- set the delay period (in hours & minutes) between each cycle
- Disable / Enable the continual cycling program.

P1	START	STOP	DELAY
06:00	21:30		00.20

In the example above, program 1 has been set to continually cycle from 6:00 hours to 21:30 hours, with a 20 minute delay between each cycle.

Disabling Continual Cycling

You can disable the continual cycling program by pressing the **Select** button when the continual cycling page is displayed. The page will change to the one shown below i.e. the start time is replaced with "NEVER".

P1	START	STOP	DELAY
NEVER	21:30		00.20

To re-enable continual cycling press the **Select** button again on this page. The start time will be redisplayed.

Other Options you May Want to Set

Using a Remote Start Sensor

You can use a sensor to control the continual cycling program. Connect the sensor to the remote start input and set Option 39 to '1' (a closed contact will start the program).

The remote start input works by immediately cutting the continual cycling delay time to zero. Therefore, you need to set the delay time to a large value so under normal operation the sensor will initiate the irrigation rather than the delay timer expiring of its own accord.

Running Multiple Continual Cycling Programs in Parallel

If you are running multiple continual cycling programs there is a possibility that two programs will overlap. Provided there is enough pressure in the system, continual cycling programs can run in parallel, by setting option 26 to '1'. If option 26 is left at '0' and continual cycling programs overlap then the overlapping program will start once the first continual cycling program has finished.

Continual Cycling - 4 Irrigation Programs (Option 34)

By setting option 34 to '1', irrigation programs 1, 2, 3 and 4 can be continually cycled. Additional pages for specifying the start, stop time of the continual cycling and a delay between cycles, one for each continual cycling program, will automatically be displayed. Default is '0'.

Continual Cycling Using Remote Start (Option 39)

This option sets Continual Cycling to use the remote start input. Set Option 39 to '1' to allow this facility. If Option 39 is set to '0', continual cycling will ignore the status of the remote start input. Default is '0'.

Priority Program (Option 29)

This allows program 1, the continual cycling program, to take priority over other irrigation programs. With this option set, if another irrigation program is running, program 1 can cut-in and run. The halted irrigation program will then continue from where it was stopped, once program 1 has completed.

If you want this facility set Option 29 to '1'. For normal operation set Option 29 to '0'. Default is '0'.

18 Wean Facility (Option 24)

The wean facility allows individual beds to be watered at less frequent intervals as plants mature. Weaning works by program one continually cycling and then Programs 2 to 4 starting at less frequent intervals based on the number of times Program 1 starts. This is described by the table below. Programs 2 to 4 run after program 1, when program 1 is running its delay period.

To activate the wean facility the following options must be set :

- Option 15 to '1' (Multiple Programs)
- Option 24 to '1' (Wean facility)
- Option 18 to '1' (Continual cycling)
- Option 26 to '1' (Parallel Programs).

Now you must set up Program 1 to continually cycle as described in the previous section. Also make sure the delay period is longer than the total irrigation times of the other programs (Programs 2 to 4), otherwise valves may come on simultaneously.

With these options set the first 4 irrigation programs will operate as follows :

Irrigation Initiated	Irrigation programs Run			
	Prog 1	Prog 2	Prog 3	Prog 4
First Time	X			
Second Time	X	X		
Third Time	X		X	
Fourth Time	X	X		X
Fifth Time	X			
Sixth Time	X	X	X	
Seventh Time	X			
Eighth Time	X	X		X
Ninth Time	X		X	

That is :

- Program 1 will start **every time** the delay time expires
- Program 2 will start every **second time** program 1 starts
- Program 3 will start every **third time** program 1 starts
- Program 4 will start every **fourth time** program 1 starts.

19 Back Flushing

The back flushing facility has the following options:-

- Back flush valve times can be set in minutes and seconds
- The back flush program can be set to run in parallel with the irrigation program or suspend the irrigation
- A delay can be set between back flush valves opening and closing.
- The back flush program can be initiated either:
 - after a delay time has expired
 - when a pressure differential is exceeded
 - a combination of both time and pressure.

Number of Back Flushing Valves (Option 9)

If Back flushing is required set option 9 to the number of back flush valves you require.

The controller will assign the last valves on the controller as the back flush valves. For example, if using an MCI-8 controller and option 9 is set to '4', valves 5 to 8 on the controller will be reserved for the back flushing.

If the back flush program is to be initiated after a fixed time delay only, no other back flush options need to be set.

Back Flush PD Only (Option 41)

If the back flush program is to be initiated once a pressure differential has been reached set Option 41 to '1'. The pressure switch should provide a closed contact when back flushing is required. The pressure switch should be connected to 'Input 1' (I1) input.

Back Flush PD and Period (Option 41)

If you require a combination of time and pressure to trigger back flushing, set option 41 to '1'. In this case back flush will be initiated when either the time expires or the pressure differential is reached.

Back Flush Priority (Option 28)

With option 28 set to '1' the irrigation program will be suspended whilst the back flushing program is run. The irrigation sequence will continue after the back flush program has completed.

Back Flush Delay Between Valves (Option 10)

If 2 or more sand filters are in operation, a delay period between back flush valves running can be specified. Set option 10 to the delay period (in seconds) required.

The Back Flush Pages

Back Flush on Time

Move to the 'Back Flush Set Up' page by repeatedly pressing the '>' button. The following page will be displayed.

BFLUSH	START	FILTER
	NEVER	00:00

To operate the back flush program you need to set:

- The time each back flush valve will operate for
- The time delay between the back flush program running.

Press '**Select**'. Enter the delay, in hours and minutes,.

Note: this time is the actual time that the pump will run before the back flush program is activated. Enter the time for each back flush valve to run, in seconds,.

In the example below, the back flush program will run after every 1hr 30 minutes of irrigation, with each filter valve running for 30 seconds.

BFLUSH	PERIOD	FILTER
	01:30	00:30

Now press the '>' button to display the Back Flush Status page. The following page shows that the main irrigation pump has operated . No back flush filters are running.

PUMP	TIME	=	0:00:00
FILTER	OFF		

When the irrigation runs the '**PUMP TIME**' counter will increase. When the specified delay between back flush programs has been reached the display will change to show the back flush valve in operation, and a count down of its remaining run-time. The pump count will return to zero, and start again. In the example below, the pump has run for 1hour and 30 minutes. The first back flush valve is in operation with 24 seconds remaining to run. The pump count has been initialized and then started to increment again.

PUMP	TIME	=	0:00:06
FILTER	1		0:24

Back Flush With Pressure Differential Only (Option 60=1)

From the t the 'Back Flush Set Up' page, press '**Select**'. The following page is displayed.

BFLUSH	START	FILTER
	PD	00:30

Set the time each back flush valve will operate for by entering the time, in seconds. Press the '>' button to display the Back Flush Status page.

PUMP	TIME	=	0:01:42
FILTER	OFF		PD OK

In the example above the Back Flush Status page shows that the irrigation has run for 1 hour and 42 minutes. During this time the pressure differential has not been reached. "PD is OK". If the pressure differential is reached the display will change as shown below:-

PUMP TIME =	0:00:06
FILTER 1	0:24

Back Flush With Pressure Differential and Time Delay

The delay between back flush programs and the time for back flush valves to run are set up as per time only operation.

Disabling Back Flush

Back Flush can be disabled at any time by first displaying the Back Flush Set Up page and then pressing the **'Select'** button. The page will display 'START NEVER' as shown below. To enable Back Flush press the **'Select'** button again.

BFLUSH	START	FILTER
	NEVER	00:00

Testing Back Flush

To test Back Flush you can press **'Manual Advance'** when the Back Flush Status page is shown. Pressing the **Manual Advance** button will either:

- Immediately end the Back Flush delay and start the Back Flush program
- Move the Back Flush program to the next valve.

20 Fertigation (Option 36)

Option 36 should be set to '1' if a fertigation operation is required. Default is '0'. Fertigation allows fresh water to be irrigated before and after the application of fertiliser.

Fertigation will control up to 32 irrigation valves and one fertiliser valve. The 2nd pump start output is automatically assigned by the controller to operate the fertiliser valve. The 2nd pump start output is across C1 and 03.

When the fertigation option is activated, each valve time on the Irrigation Program Set Up page is divided up into three time periods, period 'a', 'b' and 'c', as illustrated below.

VALVE 1a	1b	1c
05:00	10:00	05:00

The fertiliser valve will be opened when ever the 'b' time period is run. The fertiliser valve will be closed when ever the 'a' and 'c' time periods are run, and fresh water only will be irrigated, see below.

Step 1	Switch valve 1 on for 5 minutes and irrigate fresh water only.
Step 2	Leave valve 1 on and open the fertiliser valve for 10 minutes to introduce fertiliser into the irrigation line.
Step 3	Close the fertiliser valve and leave valve 1 on for another 5 minutes to irrigate fresh water only.
Step 4	Switch valve 1 off. Valve 1 has remained open for a total of 20 minutes.

Note: If you are using delay between valves (option 11) with fertigation you must set a time under 'a' for each valve you are using. It only needs to be a short time e.g. 5 seconds.

Limitations To use The fertigation option disables the manual starting of a valve and disables the use of Set All.

21 Irrigation by Volume

The volume facility allows you to set programs to be set by volume rather than time. The volume facility is designed to operate with flow meters that give a pulse for every one or ten litres of water. The pulse should be made by the closing and opening of a volt free contact. The minimum open or shut time should not be less than 0.1 seconds.

In the example below, valve 1 is set for 1100 litres and valve two for 5,000 litres with a flow meter giving one pulse per 1 litre.

VALVE	1	2	3
	1100	0500	0000

Irrigate on Volume Input 1 (Option 22)

If the flow meter is to be connected to Input 1 (across 'C2' and 'I1'), then option 37 should be set to '1'. Default is '0'.

Flow Meter or Cable Failure

If the controller does not receive a pulse for 2 minutes it will stop the irrigation program.

22 Installation Options

Remote Stop Option (Option 27)

This controls whether irrigation programs should freeze or permanently stop when the remote stop input is activated.

Set option 27 to '0' to freeze irrigation programs. Irrigation programs will start again from the point at which they stopped when the remote stop condition is removed.

Set option 27 to '1' to stop irrigation programs. Irrigation programs will not automatically start again when the remote stop condition is removed.'

'Low Tank' Display (Option 43)

Option '10' changes the remote stop input message to 'Low Tank'. To display 'Low tank' instead of 'Freeze' or 'Stop', set option '10' to '1'. Default is '0'.

Battery Fitted (Option 19)

Option 19 should always be set to '1'. This tells the controller the coin cell battery is fitted.