

HERON ELECTRIC COMPANY LTD

Basic User and Installation Manual

MCI-100S TWO WIRE DECODER CONTROLLER

Doc ref.MCI100 75BXX BASIC

Copy of this manual is at www.heron-electric.com
Price for a copy to be posted £10

TABLE OF CONTENTS

1. About This Controller	3
2. More Inputs and Outputs.....	6
3. Getting to know your controller	8
4. Setting Decoder Serial Numbers.....	9
5. Your First Irrigation Program.....	10
6. Starting and Stopping.....	12
7. A Couple of Short Cuts	14
8. Resetting the Clock.....	15
9. Fault Messages.....	16
10. Taking Care of Your Controller	17
11. Changing Configuration Options	18

1. About This Controller

The MCI-100S is a sequential irrigation controller which operates 24V AC solenoid valves via "decoders". Up to 100 decoders can be connected to the controller via a common two-wire cable.

2. Installation

WARNING Installation should be carried out by a Competent Electrician.

Mounting the MCI-100S Controller

The controller should be mounted on a wall using four screws, one screw through each corner lid bolt hole.

Warning: Additional holes should not be drilled through the controller casing.

Do not mount the controller in direct sunlight. Do not mount the controller where it can be exposed temperatures above 40 deg C.

Connecting Mains Supply

IMPORTANT. Switch off the mains supply before connecting the controller.

Check that the mains supply voltage IS the SAME AS the VOLTAGE OF the CONTROLLER. The controller voltage is displayed on the inside the controller casing. The mains supply should be fused with a 3 amp fuse and be connected via a Residual Current Circuit Breaker as per any equipment used in damp conditions.

Connect the mains supply to the three terminals inside the IEC plug Live to L, Neutral to N and Earth to E as shown in Fig 1.

Installing Decoders

Never expose decoders to direct sunlight or in locations where they be exposed to ambient temperatures of more than 38 deg C. In warmer climates this will necessitate installing in a valve box underground.

The solenoid output voltage is an **Extra Low Safety Voltage**. Keep solenoid cables and connections well away mains voltages as per regulations for Extra Low Safety Voltages .

It is recommended that a two wire water proof cable eg. polythene cable or similar, is used to connect the decoders. All cable joints must be sealed to minimise water ingress.

The controller gives out 30VAC to power 24VAC solenoids. This larger voltage allows for voltage drop in the two wire cable. If you are connecting solenoids close to the controller (less than 200m) there will be little voltage drop and you should check that the solenoids are capable of withstanding a voltage as high as 30VAC.

The decoder outputs are on the following wires. The return wire from the solenoid valves is wired to either of the red wires.

	<i>1st Serial No.</i>	<i>2nd Serial No.</i>	<i>3rd Serial No.</i>
Serial No. controls decoder output on	YELLOW wire	WHITE wire	PURPLE wire

Fig 1 Output Wiring

Black Driver Type

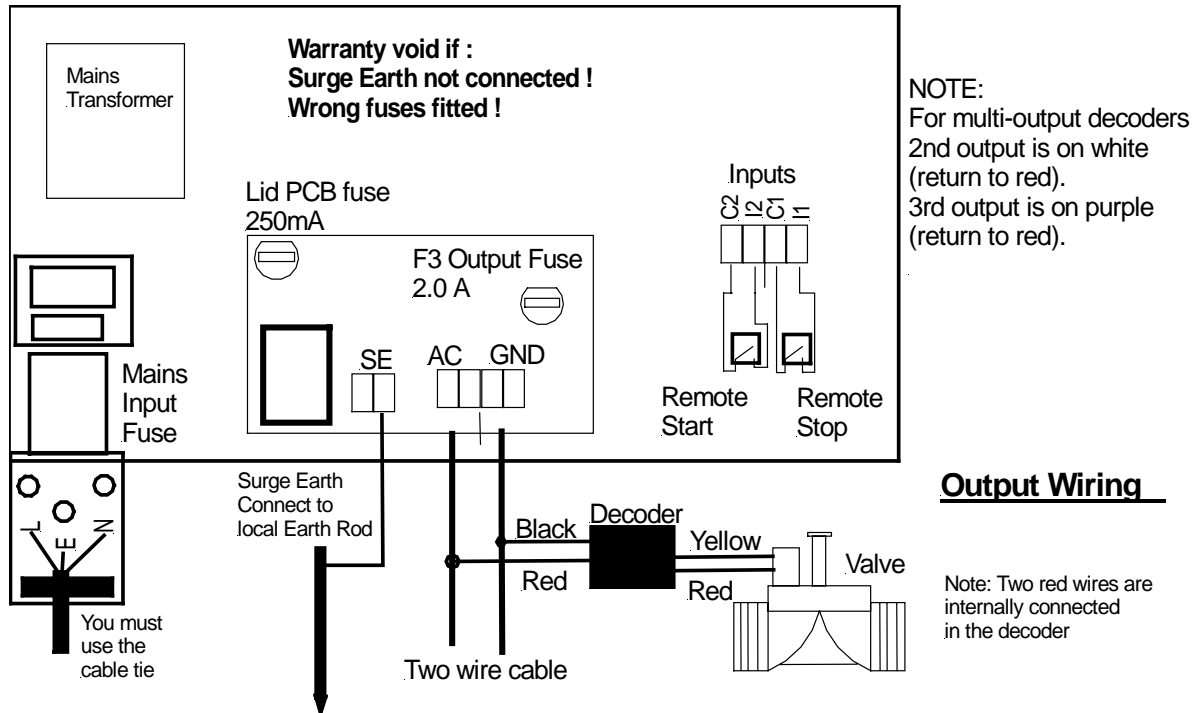

Combined Driver Type

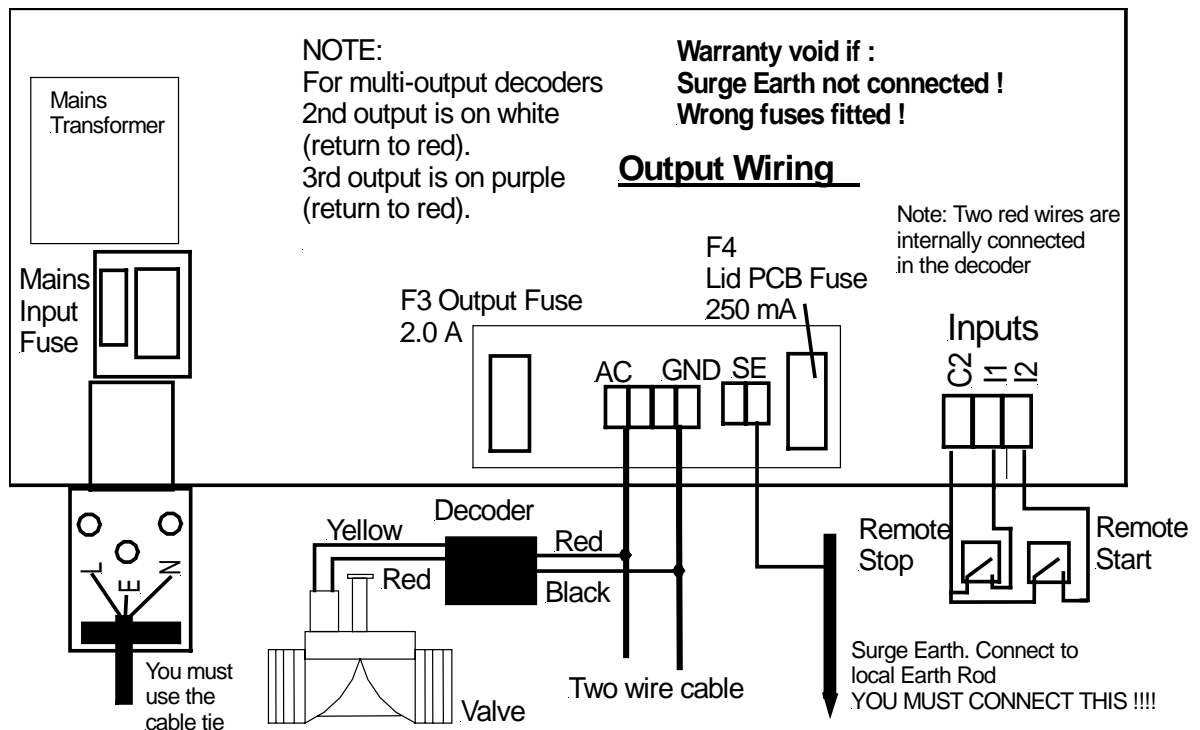

Pump Start

The MCI-100S **does not have** a pump start output. To facilitate a pump start output you must purchase a Heron Two Wire Pump Start. There are a number of options available. Never connect any relay across the two wire cable.

Cable Earth Points

Cable earth points should be wired to the cable with earth rods as also shown in Fig 2. A minimum of 3 should be installed for a looped cable and a minimum of 2 for a straight cable. Additional cable earth points should be wired every 1000 m if necessary. Failure to wire these earth points will make the controller liable to surges caused by lightning which may causes serious damage.

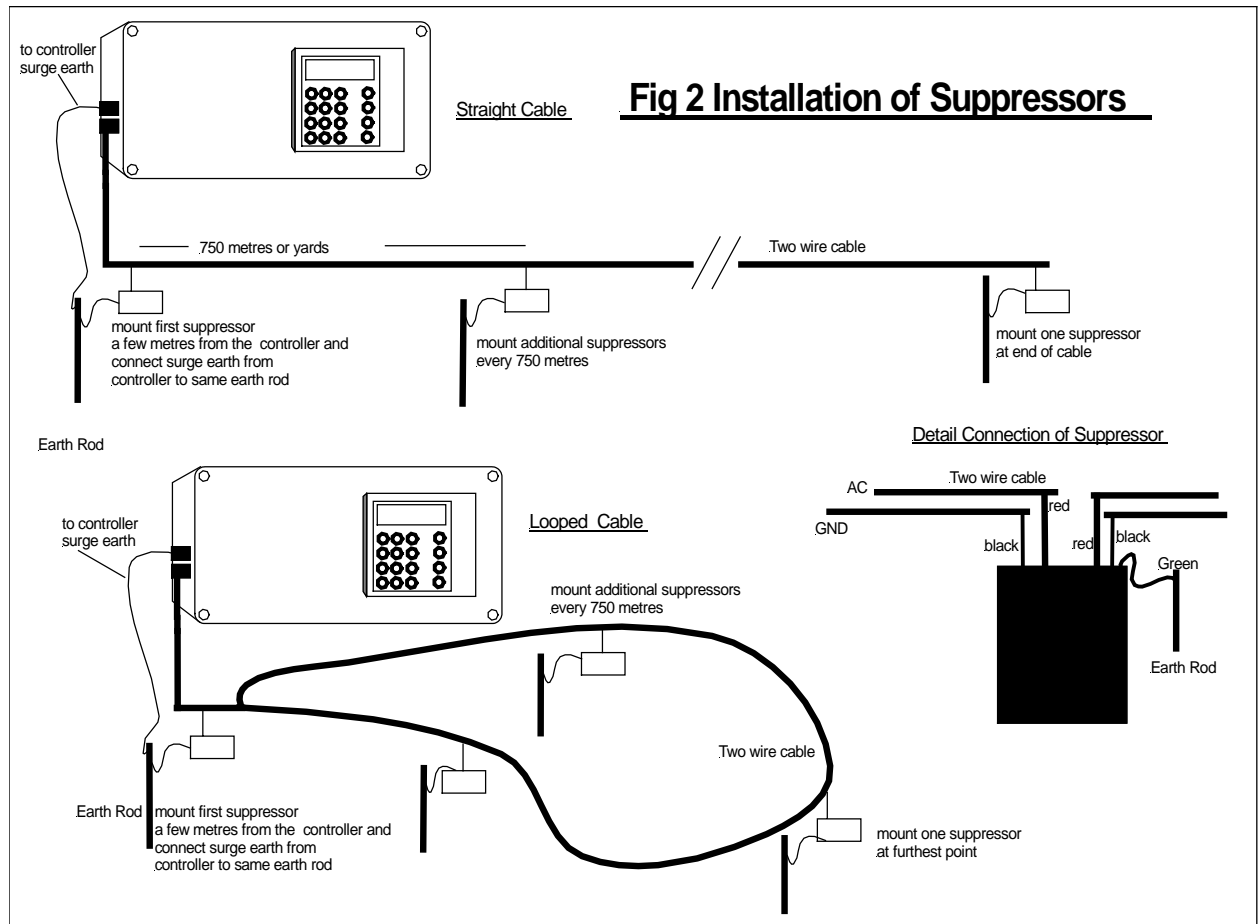

3. More Inputs and Outputs

Remote Start

The remote start input is across "I2" and "C2". Joining these terminals will start program 1. The terminals have to be connected for only a short period, 1 second, to activate the program. If the contacts are left shorted program 1 will continually cycle.

Remote Stop

The remote stop input is across "I1" and "C2". Joining these inputs halts the irrigation programs. The programs will continue once the short is removed.

This input may be connected to a float switch in the water reservoir so that the irrigation sequence is halted if the water level is low.

When the remote Stop Input is active the following messages can be displayed depending upon Options 9 and 10.

Low Tank

"Low Tank" indicates that the water level in the storage tank is low. The irrigation program will temporarily stop. Once the water tank has been filled, the irrigation program will start again.

Freeze

"Freeze" indicates that a sensor connected to the remote stop input has been activated. Once the freeze condition has been removed from the input, the irrigation program will start again from the point at which it was temporarily halted.

Stop

"Stop" indicates that a sensor connected to the remote stop input has been activated. In this case, the irrigation program will not restart when the remote stop condition is removed.

PC Connection

The PC connection is white 4 Pin connector on the top side of the processor board. (The processor board is mounted in the lid.) Plug a Heron RS232 interface onto this connector (RS232INT-B) to allow your controller to be connected to a PC running Ground Control software.

Interface Board Connection

The Interface Board Connection is Black 10 pin connector in the middle of the processor board. (The Processor board is mounted in the lid.) You can plug the following boards into this connector to allow a variety of sensors to be connected to your MCI controller:-

- Remote Start Expansion Board
- Single Analogue Interface Board
- Multi-Interface Board

Declaration of Conformity

We herewith declare that all products manufactured by the company below meet the requirements of EC directives.

Applied Standards Are:

EN 50081-1 EMC Generic Emission

EN 50082-2 EMC Generic Immunity

To comply the product must be permanently installed in accordance with the installation instructions provided and the electrical supply must be sinusoidal.

Heron Electric Co Ltd,

Unit G15 Rudford Industrial Estate, Arundel, England

USA This product has been certified as an FCC **Class B** device.

4. Getting to know your controller

When the you switch on the power the **Time Page** is displayed as shown below.

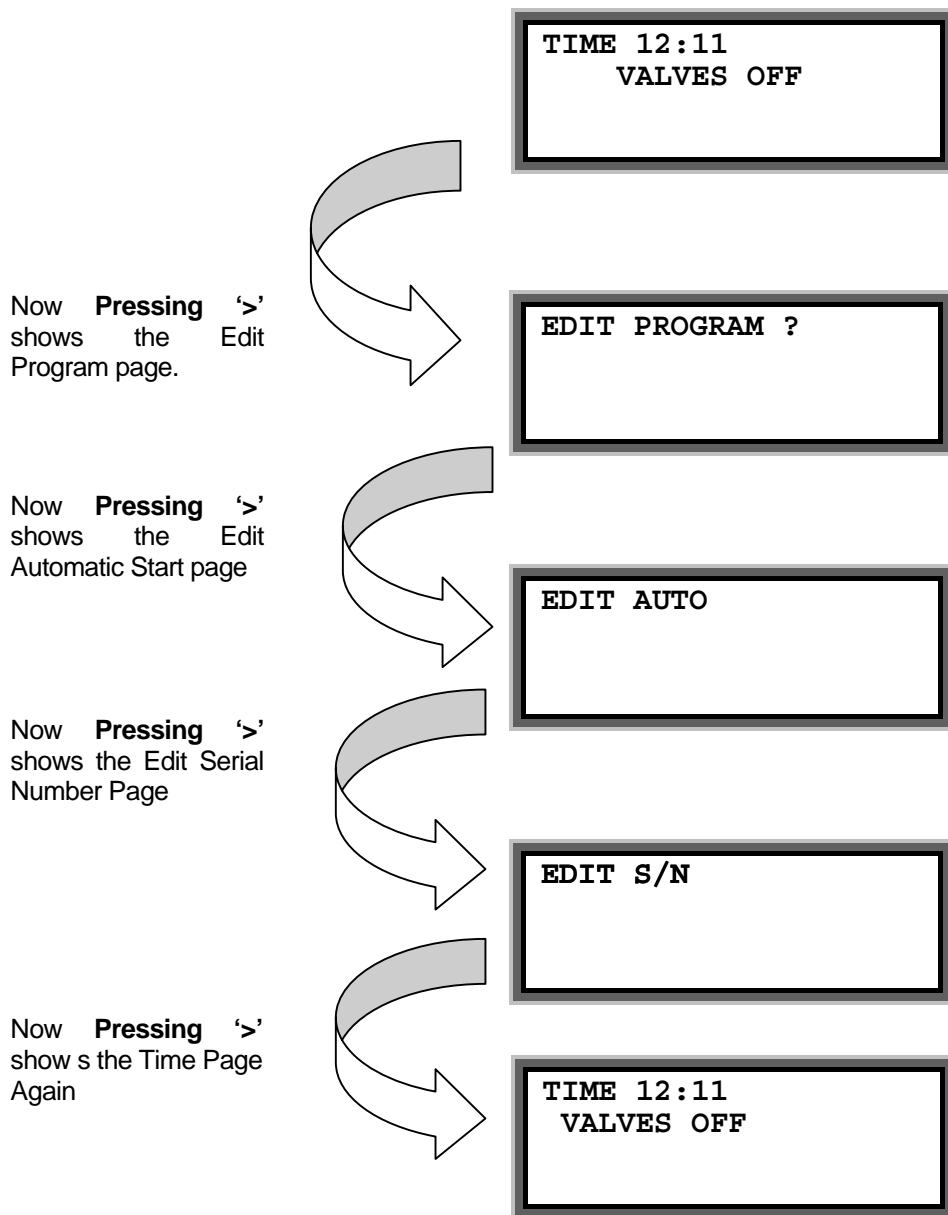

Pressing **Select** at the appropriate page will take you into either the Irrigation Programs, the Automatic Starts or the Serial Numbers.

5. Setting Decoder Serial Numbers

If you are installing the system you need to set the Decoder Serial Number of each irrigation valve .

The decoder serial number is shown on the side of each decoder. Any decoder serial number can be assigned to any valve. For example, if you have a decoder with serial number 02345 and you wish this to be valve 1 you must assign 02345 to valve 1. Proceed as follows

Press '>' until the following page is displayed

```
EDIT S/N
```

Press **'Select'** and the following page will be displayed

```
EDIT S/N 001  
VALVE 1 02345
```

Now enter the required Serial Number for valve 1, for example to 02345.

Press '>' to enter the serial numbers of other valves

To return to the Time Page press **'Return'**.

Assigning Cable Driver Number (Two-Cable Drivers Controllers Only)

If your controller has two cable drivers you need to define which cable the decoder and valve are attached to.

A controller with two cable drivers will show the cable number for each valve after the serial number. In the example below it is set to 1 which is the default value. To change this number press '>' after you have entered the serial number. Then press 1 or 2 for cable driver 1 or 2 respectively.

```
EDIT S/N 001  
VALVE 1 02345 1
```

NOTE: If the cable number is not displayed you should set Option 41 to 1, see advanced manual.

6. Your First Irrigation Program

By means of an example this section describes how to set an irrigation program and set an automatic start. The example will set **Valve 1 for 10 minutes, Valve 2 for 5minutes** in irrigation **program 1** and then set an **automatic start** to start the irrigation program at **6.00 am**.

Setting the Irrigation Program

Press '>' to display the Enter Program Page.

```
ENTER PROG 1?
```

Now press Select to edit Program 1 and a page similar to the following page will be displayed.

```
1 VALVE 01 00:00
1 VALVE 02 00:00
1 VALVE 03 00:00
1 VALVE 04 00:00
```

Suppose you want VALVE 01 to run for 10 minutes and VALVE 02 to run for 5 minutes change the page to the following.

```
1 VALVE 01 10:00
1 VALVE 02 05:00
1 VALVE 03 00:00
1 VALVE 04 00:00
```

When you have finished press the **'Return'** key.

Note: The numbers on the left column are the zone numbers These indicate what valves, if any, run together. In the above example all valves are in the same irrigation Zone (Zone 1) so no valves will run together.

Setting the Automatic Start Times - The Steps

Press '>' to display the Enter Program Page.

```
ENTER AUTOS 1?
```

Now press Select to edit the Automatic Starts

AUTO		
1	2	3
OFF	OFF	OFF
0:00	0:00	0:00

Now enter 6 under the first automatic start for 6:00 am start time.

AUTO		
1	2	3
OFF	OFF	OFF
6:00	0:00	0:00

You must now activate the start time by pressing the "Select" button whilst the flashing cursor is still positioned on the start time You will see the display above the start time change from "OFF" to "PRG1".

AUTO		
1	2	3
PRG1	OFF	OFF
6:00	0:00	0:00

"PRG1" indicates that a start time has been activated as shown above.

To enter a second automatic start time, press the arrow forward key ">" until it is positioned on the first zero of the second start.

To return to the Time Page press the 'Return' key.

Congratulations....You have now set up your first irrigation program.

7. Starting and Stopping

To manually start the **pump, a valve or an irrigation program** press 'Start/Stop' and the following page will be displayed.

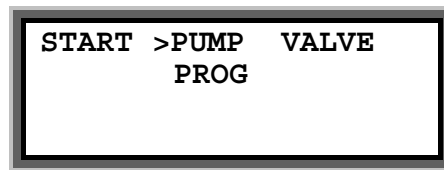

```
START >PUMP VALVE
      PROG
```

Pump Start

With the flashing arrow pointing at **"PUMP"** press **"Select"** to start Pump 1. The display below will be shown.

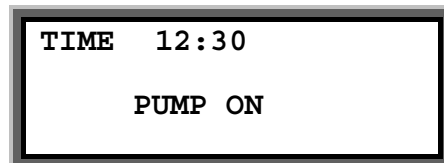

```
TIME 12:30
      PUMP ON
```

Valve Start

Press the arrow forward key ">" to position the flashing arrow to point at **"VALVE"**.

Press **"Select"** and the page below is shown.

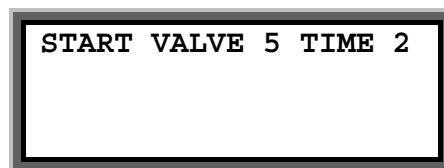

```
START VALVE 5 TIME 2
```

Enter the number of the valve to be started.

Press the ">" and then enter the number of minutes the valve is to run.

In the example above valve 5 has been set to run for 2 minutes.

Now press **"Select"** to start this valve. The **"Time Page"** will be displayed as shown below.

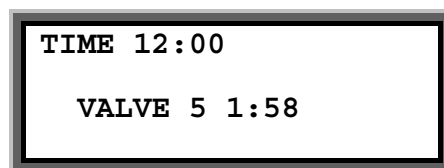

```
TIME 12:00
      VALVE 5 1:58
```

Program Start

To start an irrigation program press the arrow forward key ">" to move the flashing arrow to point at **"PROG"**. Press **"Select"** to start the irrigation program. The time page will be displayed showing the program running.

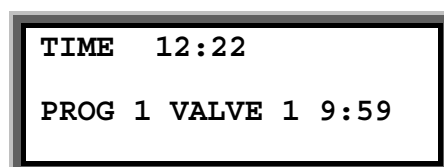

```
TIME 12:22
      PROG 1 VALVE 1 9:59
```

Manual Stop

Pressing "**Start/Stop**" at any time when a program, valve or pump is running will stop the program, valve or pump immediately.

8. A Couple of Short Cuts

Set All

When setting up an irrigation program, the **'Set All'** key is a quick method of setting a number of valves to the same time.

When the **"Enter Valve Time"** page is displayed, press the **"Set All"** key. The following page will be displayed.

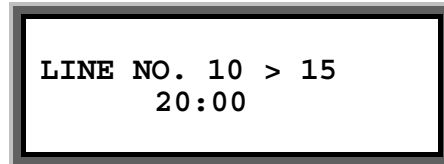

Using the arrow forward key ">" and the keypad, the range of valves to be set to the same run time, and the run time itself, can be entered. In the example shown above, valves between line number 10 and 15 have all been set to run for 20 minutes each.

The Line Number is the position in the program and is shown in the bottom right hand corner of the program page.

Pressing **"Set All"** again will return you to the program and set the times.

Manual Advance

When the irrigation program is running, press **"Manual Advance"** to move the program onto the next valve in the sequence.

This can be useful when testing your system.

9. Resetting the Clock

- Press ">" until the "Time Page" is shown.
- Now Press and hold down the "0" key for five seconds. A black flashing cursor will appear.
- Using number keys and ">" the correct time of day can be entered.
- When you have reset the time, press the ">" twice or wait 15 seconds key again. The black flashing cursor will disappear.
- The time has been reset.

Note: On controllers bought before March 2003 press and hold the **Select** button instead of '0'. Then press and hold the **Select** button to end changing the time.

10. Faults

If a fault occurs whilst the controller is running a watering program, for example a cable breaks, then the following display is shown.

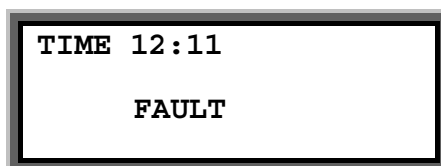

The nature of the fault is displayed by pressing '>'. The Fault Page will be displayed.

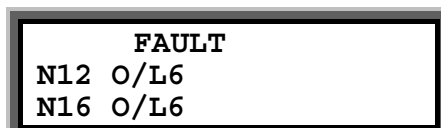

In the example above the Fault Page indicates that current Over/Load 6 (O/L6) has occurred on valves with Valve Reference Numbers 12 and 16.

IMPORTANT: To find the appropriate decoder serial number and/or valve name from the Valve Reference Number go to the Serial Number Pages.

Controller Displays	Fault	MCI-100s Response	Action
CAB O/L1	Two wire cable line loading not OK (see Testing in)	All irrigation programmes will be immediately stopped	Refer to Next Section 'Testing'
CAB O/L2	Remote Short on two wire cable (more than 1.6 amps)	All irrigation programmes will be immediately stopped	Refer to Next Section 'Testing'
CAB O/L4	Current over load when valves running (more than 1.6 amps)	Current and subsequent irrigation programmes will continue as normal . If 20 faults occur all programs will stop.	Run the program and see what valve or valves are running when the problem occurs. It is likely to be a coil short circuit on the output of a decoder or too many valves operating together. You can also set Option 51 to display the current.
Nx O/L6 x=valve reference number	Decoder output overload (more than 0.5 Amps from decoder)	Current and subsequent irrigation programmes will continue as normal . If 20 faults occur all programs will stop.	There is a short or the coil is failing on the output of the decoder . Find the decoder with the 'valve reference number', then disconnect the coil from the decoder and test again.
Nx DECO x=valve reference number	No acknowledgement from decoder when switching on	Current and subsequent irrigation programmes will continue as normal . If 20 faults occur all programs will stop.	Find the decoder with the 'valve reference number'. Check decoder serial number is correct. Check decoder is connected and is connected the correct way round. Finally try the decoder locally at the controller.
Nx OFF x=valve reference number	No acknowledgement from decoder when switching off	All irrigation programmes will be immediately stopped	Find the decoder with the 'valve reference number'. Retry the decoder many times to see if problem repeats. Check joints to decoder. If decoders still fails try decoder locally at the controller.

Clearing Fault Conditions

The fault page is cleared by manually starting and stopping an irrigation program.

Optical Fault

If 'OPTICAL FAULT' is displayed it means that the optical link is not working correctly. Check that F3 is not blown.

11. Taking Care of Your Controller

Never - use sharp objects to press the buttons on your controller. Avoid pressing the buttons with your finger nails.

Always - ensure the lid screws are screwed down tightly to keep the inside of the controller dry and to reduce exposure to high humidity.

Leave Mains Power On Over the Winter - to keep the controller warm and prevent the inside of the casing becoming damp.

12. Changing Configuration Options

This section describes the basic options you can set on your controller. There are just 15 basic options. If you need to use the more advanced features please refer to the 'Advanced Options' manual.

To access the configuration options press and hold down "**Manual Advance**" button for **10 seconds**. The following page will be displayed.

OPTION		
1	2	3
8	3	0

The arrow forward key ">" is used to position the cursor under the option you want to change. Use the keypad to enter the required number, as described below, to activate the option.

In the example above, Option's 1,2 and 3 have been set to 8, 3 and 0. When the required options have been set, press the arrow forward ">" or arrow backward key "<" repeatedly until the 'Time' page is shown.

Note: You irrigation installer or dealer may have already set the configuration options to the required values for you.

The 15 basic options are listed below.

Option	Brief Description	Default Value
Option 1	Set number of valves.	48
Option 2	Set number of Daily automatic starts.	0
Option 3	Set number of Weekly automatic starts.	3
Option 4	The number of irrigation programs	1
Option 5	Set pump pressurisation time in minutes.	0
Option 6	Set pump pressurisation time in seconds.	2
Option 7	Rain sensor connected and number of historical rain days	0
Option 8	The Day of the week (1 = Monday, 2 = Tuesday)	1-7
Option 9	Controller does a permanent Stop instead of Freeze	0
Option 10	Display Low Tank instead of Freeze or Stop	0
Option 11	Use Percentage Up and Down	0
Option 12	Spare	0
Option 13	Use 'Disable Automatic Starts' facility	0
Option 14	Spare	0
Option 15	DISPLAY ADVANCED OPTIONS (OPTIONS 16 TO 77)	0

Number of Valves (Option 1)

Option 1 is maximum number of valves you can assign and the maximum number of valves in a program. Set it to the maximum number of decoders you wish to assign.

Number of Daily Automatic Starts (Option 2)

If you need to increase or decrease the number of Daily automatic starts change Option 2. Enter the required number under Option 2. There will be no change to the operation of the controller just more Daily automatic start pages will be displayed. (Values between 0 and 30 are allowed).

Number of Weekly Automatic Starts (Option 3)

If you need to increase or decrease the number of Weekly automatic starts change Option 3. Enter the required number under Option 3. Values between 0 and 32 are allowed.

When weekly programming is selected an additional page will be displayed for each automatic start. An example is shown below.

AUTO 4	EXIT
OFF	MON AT 0:00

- To enable the automatic start move the cursor under 'OFF'. Now press the **Select** button to select the program.
- To set the day of the week move the cursor under **MON**. and press the **Select button** repeatedly to change the day of the week.
- Set the time move the cursor under the time and change it.

AUTO 4
PRG1 TUE AT 12:00

In the example above Program 1 will start at 12:00 on Tuesday.

Number of Irrigation Programs (Option 4)

Set option 4 to the number of irrigation programs you need. A maximum of 16 irrigation programs are allowed. If this is option is not set the controller will use just one irrigation program.

Once you have set this option you can then modify and use more than one irrigation program. Modification of additional irrigation programs is exactly the same as modifying Irrigation Program 1. All you have to do is set the number of the program you want to edit.

Pump Pressurisation Time in Minutes (Option 5)

The pump pressurisation time (in minutes) can be set with Option 5. (Values between 0 and 99 minutes are allowed).

Pump Pressurisation Time in Seconds (Option 6)

The pump pressurisation time (in seconds) can be set with Option 6. (Values between 0 and 99 seconds are allowed).

Rain Sensor to Reduce Watering (7)

The Heron rain sensor allows the irrigation program to be reduced depending on the amount of rain that has fallen over the last few days. Two trip points can be set.

If you have a rain sensor, set Option 7 to the number of days you wish the rain sensor to work over. For example if you set Option '7' to 3 then rain that has fallen within the last 3 days will still be included in the rain fall measurement. The maximum value you can set option 7 to is 4.

Setting Option 7 to zero will disable the rain sensor.

Connecting the Rain Sensor

Connect the two terminals inside the rain sensor to Input 2 (across "I2" and "C2"). The terminals in the rain sensor are accessed by removing the bottom of the rain sensor.

Using the Rain Sensor

When option 7 is set, the rain page is displayed after the Automatic Start pages. Press ">" or "<" to view the page. The rain page is shown below.

RAIN FALL 2mm		
ADJ	50%	100%
TRIP	4	9

On the rain page you can set two trip points in mm of rain fall. When these trip points are met irrigation programs will run for either :

- 50% (half) of their normal time
- 0% of their normal time (i.e. not run).

To set a trip point move the cursor under the appropriate percentage (50%, or 0%) and enter a number . In the example above trip points have been set at 4 mm and 9 mm.

Testing the Rain Sensor

The rain sensor can be tested by pressing the spoon down inside the rain sensor . Pressing the spoon down every 10 seconds will increment the rain fall by 1 mm. If you press the spoon enough times so that a trip level is reached you will see a reduction in the irrigation watering programs.

Note:

- The rain sensor has no effect on a manual valve start
- One minute must elapse before the percentage reduction will be registered after the threshold is reached.

Setting the Day of the Week (Option 8)

The current day of the week for weekly automatic starts should not normally need changing. If you do need to change the day of the week set Option 8 to 1 for Monday, 2 for Tuesday, 3 for Wednesday etc.

Remote Stop Option (Option 9)

This controls whether irrigation programs should freeze or permanently stop when the remote stop input is activated.

Set option 9 to '0' to freeze irrigation programs. Irrigation programs will start again from the point at which they stopped when the remote stop condition is removed.

Set option 9 to '1' to stop irrigation programs. Irrigation programs will not automatically start again when the remote stop condition is removed.'

'Low Tank' Display (Option 10)

Option '10' changes the remote stop input message to 'Low Tank'. To display 'Low tank' instead of 'Freeze' or 'Stop', set option '10' to '1'. Default is '0'.

Percentage Up and Down (Option 11)

Percentage Up and Down allows all irrigation run times to be temporarily adjusted by a specified percentage (0%-250%). With Option 25 set to '1' the following page will be displayed after the Automatic Start pages.

If no increase or decrease is required, then the percentage value must be set to 100%.

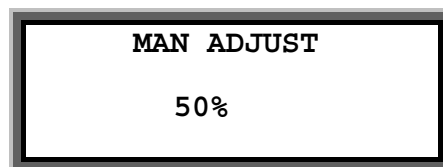

In the example above irrigation programs will run for half their normal time.

IMPORTANT: Do not leave the percentage value at 0%. No irrigation will run.

Automatic Start disable (Option 13)

Option 13 allows all automatic starts to be disabled by pressing and **Holding** the **Select** key when on the Time page. When automatic starts are active the controller will display the following:-

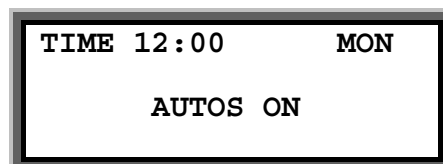

If the **Select** key is pressed the controller will then display the following and all automatic starts will be disabled until the **Select** key is pressed again.

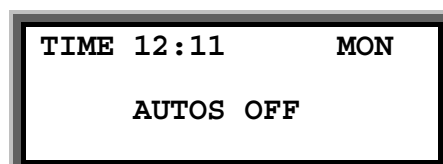

Enable and Display Advanced Options (Option 15)

If you wish to use the 'Advanced Options' set Option 15 to 1. Advanced Options are Options 16 onwards.

With option 15 set at 0 you will not be able to access the Advanced Options. Furthermore, the controller will ignore the value of all Advanced Options if Option 15 is 0.