

HERON ELECTRIC COMPANY LTD

# Basic User and Installation Manual

MCI-100S TWO WIRE DECODER CONTROLLER

---

Doc ref.MCI100 74A1 BASIC

Copy of this manual is at [www.heron-electric.com](http://www.heron-electric.com)

Price for a copy to be posted £10

# TABLE OF CONTENTS

1.	<i>About This Controller</i> .....	<i>ii</i>
2.	<i>More Inputs and Outputs</i> .....	<i>vii</i>
3.	<i>Getting to know your controller</i> .....	<i>viii</i>
4.	<i>Setting Decoder Serial Numbers</i> .....	<i>ix</i>
5.	<i>Your First Irrigation Program</i> .....	<i>xi</i>
6.	<i>Starting and Stopping</i> .....	<i>xiii</i>
7.	<i>A Couple of Short Cuts</i> .....	<i>xv</i>
8.	<i>Resetting the Clock</i> .....	<i>xvi</i>
9.	<i>Fault Messages</i> .....	<i>xvii</i>
10.	<i>Taking Care of Your Controller</i> .....	<i>xix</i>
11.	<i>Changing Configuration Options</i> .....	<i>xx</i>

## 1 About This Controller

The MCI-100S is a sequential irrigation controller which operates 24V AC solenoid valves via "decoders". Up to 100 decoders can be connected to the controller via a common 2-core cable.

### Switching on the Display

The LCD display is switched on by pressing and holding down the **Set All** key for 2 seconds. You can do this without the mains power connected.

## 2 Installation

**WARNING** Installation should be carried out by a Competent Electrician.

### Mounting the MCI-100S Controller

The controller should be mounted on a wall using four screws, one screw through each corner lid bolt hole.

Warning: Additional holes should not be drilled through the controller casing.

### Connecting Mains Supply

**IMPORTANT SAFETY CHECK.** Check that the mains supply voltage IS the SAME AS the VOLTAGE OF the CONTROLLER. The controller voltage is displayed on the inside the controller casing. The mains supply should be fused with a 3 amp fuse and be connected via a Residual Current Circuit Breaker as per any equipment used in damp conditions. Connect the mains supply to the three terminals as shown in Fig 1, L to Live, N to Neutral, E to Earth.

### Connecting Decoders

Connect decoders as per diagram Fig 1.

It is recommended that a 2-core water proof cable eg. polythene cable or similar, is used to connect the decoders. The cable must **NOT** be installed near mains voltage cables. Interference may result from externally induced voltages. All cable joints must be sealed to minimise water ingress.

The controller gives out 30VAC to power 24VAC solenoids. This larger voltage allows for voltage drop in the 2 core cable. If you are connecting solenoids close to the controller (less than 200m) there will be little voltage drop and you should check that the solenoids are capable of withstanding a voltage as high as 30VAC.

Two and three output decoders have outputs as follows:-

	<i>1st Serial No.</i>	<i>2nd Serial No.</i>	<i>3<sup>rd</sup> Serial No.</i>
Serial No. controls decoder output on	YELLOW wire	WHITE wire	PURPLE wire

The return wire from the solenoid valves are wired to either of the red wires.

## Cable Earth Points

Cable earth points should be wired to the cable with earth rods as also shown in Fig 2. A minimum of 3 should be installed for a looped cable and a minimum of 2 for a straight cable. Additional cable earth points should be wired every 1000 m if necessary. Failure to wire these earth points will make the controller liable to surges caused by lightning which may cause serious damage.

## Battery Supply

The processor board is powered from 4xC size alkaline batteries. These batteries will last between 2 to 4 years. When the batteries run low the controller will display "LOW BATTERY".

## Pump Start (24VAC)

The pump start output is across the terminals marked 'Pump'. This output is rated at 24VAC 0.5A.

## Infra Red Link

The processor board (mounted in the lid of the controller) is completely isolated from the 2-wire line driver.

The processor board communicates with the line driver via an optical link. Nothing should be placed in the way of this link or in the isolation zone as shown on Fig 1.

# Non USA Wiring Diagram

## Fig 1 Output Wiring

Note: Two red wires are internally connected in the decoder

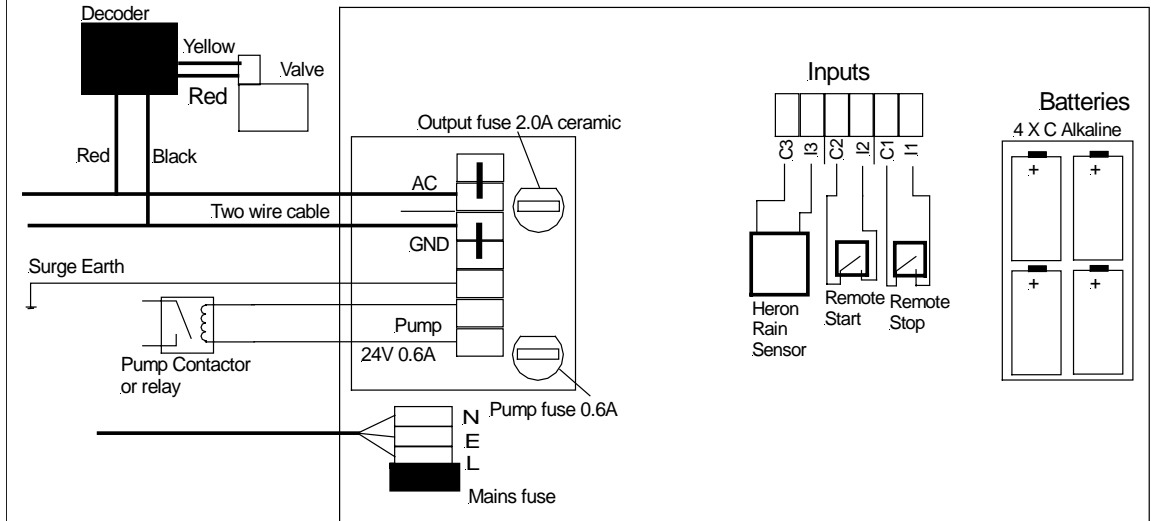

Warranty void if wrong fuses fitted !

# USA ONLY Wiring Diagram

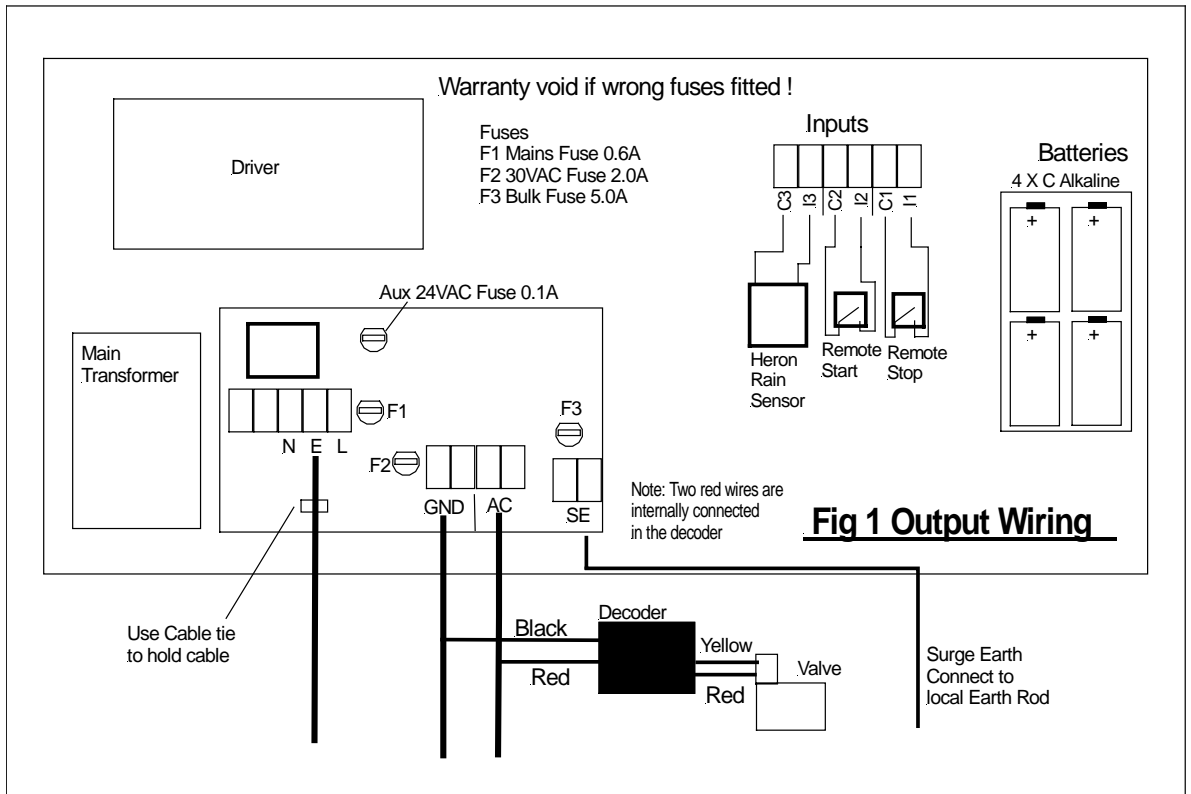

# Fig 2 Installation of Suppressors

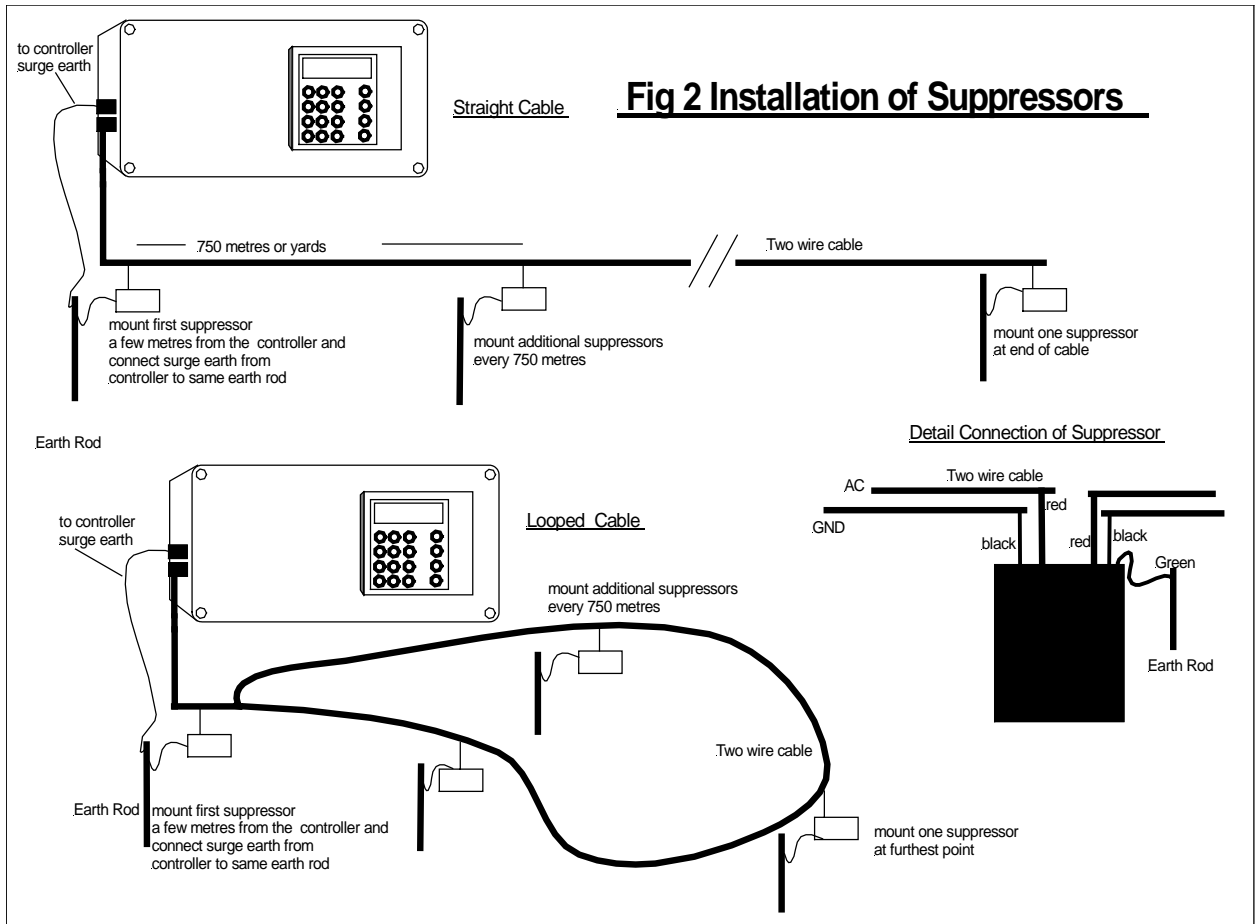

### 3 More Inputs and Outputs

#### Remote Start

The remote start input is across "I2" and "C2". Joining these terminals will start program 1. The terminals have to be connected for only a short period, 1 second, to activate the program. If the contacts are left shorted program 1 will continually cycle.

#### Remote Stop / Low Water Cut Out

The remote stop input is across "I1" and "C1". Joining these inputs halts the irrigation programs. The programs will continue once the short is removed.

This input may be connected to a float switch in the water reservoir so that the irrigation sequence is halted if the water level is low.

#### Rain Sensor Input

The Heron rain sensor input is across "I3" and "C3". Only a heron rain sensor can be connected to these terminals.

When the you switch on the power the **Time Page** is displayed as shown below.

## 4 Getting to know your controller

Now **Pressing** '>' shows the Edit Program page.

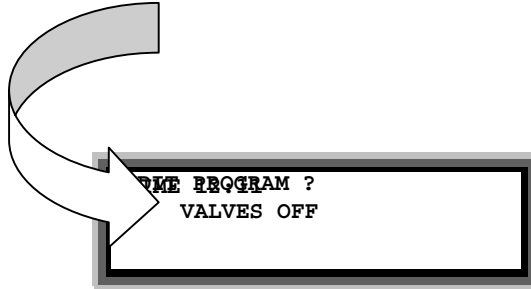

Now **Pressing** '>' shows the Edit Automatic Start page

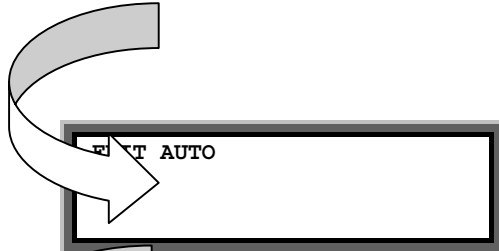

Now **Pressing** '>' shows the Edit Serial Number Page

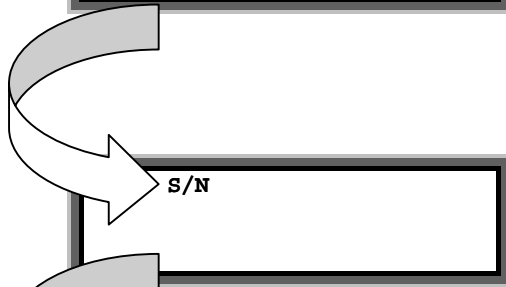

Now **Pressing** '>' shows the Time Page Again

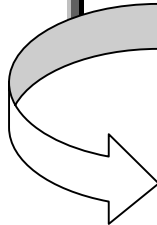

Pressing **Select** at the appropriate page will take you into either the Irrigation Programs, the Automatic Starts or the Serial Numbers.

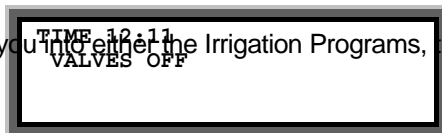

## 5 Setting Decoder Serial Numbers

If you are installing the system you need to set the Decoder Serial Number of each irrigation valve .

The decoder serial number is shown on the side of each decoder. Any decoder serial number can be assigned to any valve. For example, if you have a decoder with serial number 02345 and you wish this to be valve 1 you must assign 02345 to valve 1. Proceed as follows

Press '>' until the following page is displayed

```
EDIT S/N
```

Press **Select** and the following page will be displayed

```
EDIT S/N 001  EXIT
VALVE  1  02345
```

Now enter the required Serial Number for valve 1, for example to 02345.

Press '>' to enter the serial numbers of other valves

Move the cursor over the EXIT position and press **Select** when you have finished

### Assigning Cable Driver Number (Two-Cable Drivers Controllers Only)

If your controller has two cable drivers you need to define which cable the decoder and valve are attached to.

A controller with two cable drivers will show the cable number for each valve after the serial number. In the example below it is set to 1 which is the default value. To change this number press '>' after you have entered the serial number. Then press 1 or 2 for cable driver 1 or 2 respectively.

```
EDIT S/N 001  EXIT
VALVE  1  02345  1
```

NOTE: If the cable number is not displayed you should set Option 41 to 1, see advanced manual.

## 6 Your First Irrigation Program

By means of an example this section describes how to set an irrigation program and set an automatic start. The example will set **Valve 1 for 10 minutes, Valve 2 for 5minutes** in irrigation **program 1** and then set an **automatic start** to start the irrigation program at **6.00 am**.

### Setting the Irrigation Program

Press '>' to display the Enter Program Page.

```
ENTER PROG 1?
```

Now press Select to edit Program 1 and a page similar to the following page will be displayed.

```
1 VALVE 01 00:00 EX
1 VALVE 02 00:00
1 VALVE 03 00:00
1 VALVE 04 00:00
```

Suppose you want VALVE 01 to run for 10 minutes and VALVE 02 to run for 5 minutes change the page to the following.

```
1 VALVE 01 10:00 EX
1 VALVE 02 05:00
1 VALVE 03 00:00
1 VALVE 04 00:00
```

When you have finished move the cursor over EX and press **Select**.

**Note:** The numbers on the left column are the zone numbers These indicate what valves, if any, run together. In the above example all valves are in the same irrigation Zone (Zone 1) so no valves will run together.

### Setting the Automatic Start Times - The Steps

Press '>' to display the Enter Program Page.

```
ENTER AUTOS 1?
```

Now press Select to edit the Automatic Starts

```
      AUTO      EXIT
1       2       3
OFF      OFF      OFF
0:00    0:00    0:00
```

Now enter 6 under the first automatic start for 6:00 am start time.

```
      AUTO      EXIT
1       2       3
OFF      OFF      OFF
6:00     0:00    0:00
```

You must now activate the start time by pressing the **Select** button whilst the flashing cursor is still positioned on the start time You will see the display above the start time change **from "OFF" to "PRG1"**.

```
      AUTO      EXIT
1       2       3
PRG1     OFF      OFF
6:00     0:00    0:00
```

**"PRG1"** indicates that a start time has been activated as shown above.

To enter a second automatic start time, press the arrow forward key ">" until it is positioned on the first zero of the second start.

Press the arrow forward key ">" to place the cursor over EXIT and press **Select..**

**Congratulations....You have now set up your first irrigation program.**

## 7 Starting and Stopping

To manually start the **pump, a valve or an irrigation program** press 'Start/Stop' and the following page will be displayed.

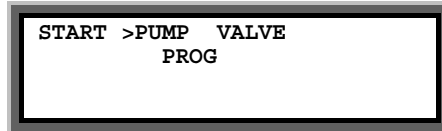

A rectangular display box with a double border containing the text: START >PUMP VALVE  
PROG

### Pump Start

With the flashing arrow pointing at "**PUMP**" press "**Select**" to start Pump 1. The display below will be shown.

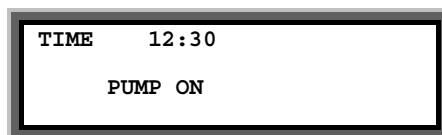

A rectangular display box with a double border containing the text: TIME 12:30  
PUMP ON

### Valve Start

Press the arrow forward key ">" to position the flashing arrow to point at "**VALVE**".

Press "**Select**" and the page below is shown.

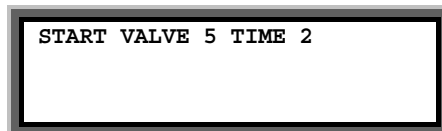

A rectangular display box with a double border containing the text: START VALVE 5 TIME 2

Enter the number of the valve to be started.

Press the ">" and then enter the number of minutes the valve is to run.

In the example above valve 5 has been set to run for 2 minutes.

Now press "**Select**" to start this valve. The "**Time Page**" will be displayed as shown below.

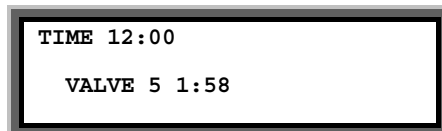

A rectangular display box with a double border containing the text: TIME 12:00  
VALVE 5 1:58

### Program Start

To start an irrigation program press the arrow forward key ">" to move the flashing arrow to point at "**PROG**". Press "**Select**" to start the irrigation program. The time page will be displayed showing the program running.

TIME	12:22
PROG 1 VALVE 1	9:59

## Manual Stop

Pressing "**Start/Stop**" at any time when a program, valve or pump is running will stop the program, valve or pump immediately.

## 8 A Couple of Short Cuts

### Set All

When setting up an irrigation program, the '**Set All**' key is a quick method of setting a number of valves to the same time.

When the "**Enter Valve Time**" page is displayed, press the "**Set All**" key. The following page will be displayed.

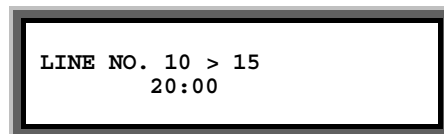

Using the arrow forward key ">" and the keypad, the range of valves to be set to the same run time, and the run time itself, can be entered. In the example shown above, valves between line number 10 and 15 have all been set to run for 20 minutes each.

The Line Number is the position in the program and is shown in the bottom right hand corner of the program page.

Pressing "**Set All**" again will return you to the program and set the times.

### Manual Advance

When the irrigation program is running, press "**Manual Advance**" to move the program onto the next valve in the sequence.

This can be useful when testing your system.

## 9 Resetting the Clock

- Press ">" until the "Time Page" is shown.
- Now Press and hold down the "Select" key for five seconds. A black flashing cursor will appear.
- Using number keys and ">" the correct time of day can be entered.
- When you have reset the time, press the "Select" key again. The black flashing cursor will disappear.
- The time has been reset.

## 10 Fault Messages

If a fault occurs whilst the controller is running a watering program, for example a cable breaks, then the following display is shown.

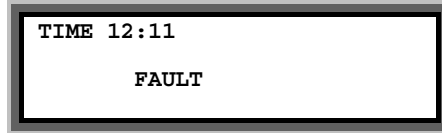

The nature of the fault is displayed by pressing '>' to view the 'Fault

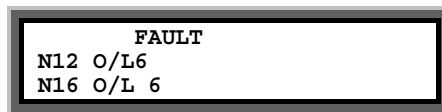

IMPORTANT: In the example above the faults are on valves with reference numbers 12 and 16.

The following eight fault types can be detected:-

	Fault	Controller Displays
1	2 core cable line loading not OK	CAB OL/1
2	Remote Short on 2 core cable (more than 1.6 amps)	CAB OL/2
3	Direct Short on main 2 core cable (more than 6 amps)	CAB OL/3
4	Current over load when valves running (more than 1.6 amps)	CAB OL/4
5	Large Current overload when valves running (more than 6 amps)	CAB OL/5
6	Decoder output overload (more than 0.6 Amps from decoder)	NxOL/6 x=val ref number
7	No acknowledgement from decoder when switching on	Nx DECO x=val ref number
8	No acknowledgement from decoder when switching off	Nx OFF x=val ref number

In the example above the fault page indicates that current overload fault number '6' has occurred on both valves number 12 and 16

### Faults 1 to 3

If faults '1' to '3' occur all irrigation programmes will be immediately stopped as it is impossible for the controller to communicate with decoders.

#### **Faults 4 to 6**

If faults 4 to 6 occur the current and subsequent irrigation programmes will continue as normal. However if a total of 20 occurrences of faults '4' to '6' are reported all irrigation programmes will be suspended .

#### **Faults 7 and 8**

If a decoder fault is reported, the current and subsequent irrigation programmes will continue as normal. However if a total of 20 occurrences of the faults are reported all irrigation programmes will be suspended .

### **Clearing Fault Conditions**

The fault page is cleared by manually starting and stopping an irrigation program.

### **POWER FAULTS**

The controller will display 'OPTICAL FAULT ' when there is no mains power or when the optical link is not working correctly.

The controller will display 'LOW BATTERY' when the battery power is low. Replace the 4 x C size alkaline batteries.

### **Low Tank**

“Low Tank” indicates that the water level in the storage tank is low.

The irrigation program will temporarily stop. Once the water tank has been filled, the irrigation program will start again.

### **Freeze**

“Freeze” indicates that a sensor connected to the remote stop input has been activated.

Once the freeze condition has been removed from the input, the irrigation program will start again from the point at which it was temporarily halted.

### **Stop**

“Stop” indicates that a sensor connected to the remote stop input has been activated. In this case, the irrigation program will not restart when the remote stop condition is removed.

## 11 Taking Care of Your Controller

**Never** - use sharp objects to press the buttons on your controller. Avoid pressing the buttons with your finger nails.

**Always** - ensure the lid screws are screwed down tightly to keep the inside of the controller dry and to reduce exposure to high humidity.

**Leave Mains Power On** Over the Winter - to keep the controller warm and prevent the inside of the casing becoming damp.

## 12 Changing Configuration Options

This section describes the basic options you can set on your controller. There are just 15 basic options. If you need to use the more advanced features please refer to the 'Advanced Options' manual.

To access the configuration options press and hold down "**Manual Advance**" button for **10 seconds**. The following page will be displayed.

OPTION		
1	2	3
8	3	0

The arrow forward key ">" is used to position the cursor under the option you want to change. Use the keypad to enter the required number, as described below, to activate the option.

In the example above, Option's 1,2 and 3 have been set to 8, 3 and 0. When the required options have been set, press the arrow forward ">" or arrow backward key "<" repeatedly until the 'Time' page is shown.

**Note:** Your irrigation installer or dealer may have already set the configuration options to the required values for you.

The 15 basic options are listed below.

Option	Brief Description	Default Value
Option 1	Set number of valves.	48
Option 2	Set number of Daily automatic starts.	0
Option 3	Set number of Weekly automatic starts.	3
Option 4	The number of irrigation programs	1
Option 5	Set pump pressurisation time in minutes.	0
Option 6	Set pump pressurisation time in seconds.	2
Option 7	Rain sensor connected and number of historical rain days	0
Option 8	The Day of the week (1 = Monday, 2 = Tuesday)	1-7
Option 9	Controller does a permanent Stop instead of Freeze	0
Option 10	Display Low Tank instead of Freeze or Stop	0
Option 11	Use Percentage Up and Down	0
Option 12	Valve times in Hours and Minutes	0
Option 13	Use 'Disable Automatic Starts' facility	0
Option 14	Spare	0
Option 15	DISPLAY ADVANCED OPTIONS (OPTIONS 16 TO 72)	0

## Number of Valves (Option 1)

Option 1 is maximum number of valves you can assign and the maximum number of valves in a program. Set it to the maximum number of decoders you wish to assign.

## Number of Daily Automatic Starts (Option 2)

If you need to increase or decrease the number of Daily automatic starts change Option 2. Enter the required number under Option 2. There will be no change to the operation of the controller just more Daily automatic start pages will be displayed. (Values between 0 and 30 are allowed).

## Number of Weekly Automatic Starts (Option 3)

If you need to increase or decrease the number of Weekly automatic starts change Option 3. Enter the required number under Option 3. Values between 0 and 32 are allowed.

When weekly programming is selected an additional page will be displayed for each automatic start. An example is shown below.

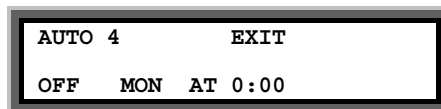

```
AUTO 4      EXIT
OFF  MON  AT 0:00
```

- To enable the automatic start move the cursor under 'OFF'. Now press the **Select** button to select the program.
- To set the day of the week move the cursor under **MON.** and press the **Select button** repeatedly to change the day of the week.
- Set the time move the cursor under the time and change it.

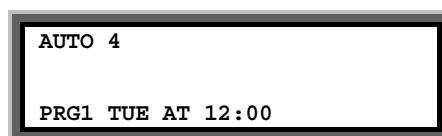

```
AUTO 4
PRG1 TUE AT 12:00
```

In the example above Program 1 will start at 12:00 on Tuesday.

## Number of Irrigation Programs (Option 4)

Set option 4 to the number of irrigation programs you need. A maximum of 16 irrigation programs are allowed. If this is option is not set the controller will use just one irrigation program.

Once you have set this option you can then modify and use more than one irrigation program. Modification of additional irrigation programs is exactly the same as modifying Irrigation Program 1. All you have to do is set the number of the program you want to edit.

## Pump Pressurisation Time in Minutes (Option 5)

The pump pressurisation time (in minutes) can be set with Option 5. (Values between 0 and 99 minutes are allowed).

## Pump Pressurisation Time in Seconds (Option 6)

The pump pressurisation time (in seconds) can be set with Option 6. (Values between 0 and 99 seconds are allowed).

## Rain Sensor to Reduce Watering (7)

The Heron rain sensor allows the irrigation program to be reduced depending on the amount of rain that has fallen over the last few days. Two trip points can be set.

If you have a rain sensor, set Option 7 to the number of days you wish the rain sensor to work over. For example if you set Option '7' to 3 then rain that has fallen within the last 3 days will still be included in the rain fall measurement. The maximum value you can set option 7 to is 4.

Setting Option 7 to zero will disable the rain sensor.

### Connecting the Rain Sensor

Connect the two terminals inside the rain sensor to Input 2 (across "I3" and "C3" ). The terminals in the rain sensor are accessed by removing the bottom of the rain sensor.

### Using the Rain Sensor

When option 7 is set, the rain page is displayed after the Automatic Start pages. Press ">" or "<" to view the page. The rain page is shown below.

RAIN FALL 2mm			
ADJ	50%	100%	TRIP
4		9	

On the rain page you can set two trip points in mm of rain fall. When these trip points are met irrigation programs will run for either :

- 50% (half) of their normal time
- 0% of their normal time (i.e. not run).

To set a trip point move the cursor under the appropriate percentage (50%, or 0%) and enter a number . In the example above trip points have been set at 4 mm and 9 mm.

### Testing the Rain Sensor

The rain sensor can be tested by pressing the spoon down inside the rain sensor . Pressing the spoon down every 10 seconds will increment the rain fall by 1 mm. If you press the spoon enough times so that a trip level is reached you will see a reduction in the irrigation watering programs.

**Note:**

- The rain sensor has no effect on a manual valve start
- One minute must elapse before the percentage reduction will be registered after the threshold is reached.

## Setting the Day of the Week (Option 8)

The current day of the week for weekly automatic starts should not normally need changing. If you do need to change the day of the week set Option 8 to 1 for Monday, 2 for Tuesday, 3 for Wednesday etc.

## Remote Stop Option (Option 9)

This controls whether irrigation programs should freeze or permanently stop when the remote stop input is activated.

Set option 9 to '0' to freeze irrigation programs. Irrigation programs will start again from the point at which they stopped when the remote stop condition is removed.

Set option 9 to '1' to stop irrigation programs. Irrigation programs will not automatically start again when the remote stop condition is removed.'

## 'Low Tank' Display (Option 10)

Option '10' changes the remote stop input message to 'Low Tank'. To display 'Low tank' instead of 'Freeze' or 'Stop', set option '10' to '1'. Default is '0'.

## Percentage Up and Down (Option 11)

Percentage Up and Down allows all irrigation run times to be temporarily adjusted by a specified percentage (0%-250%). With Option 25 set to '1' the following page will be displayed after the Automatic Start pages.

If no increase or decrease is required, then the percentage value must be set to 100%.

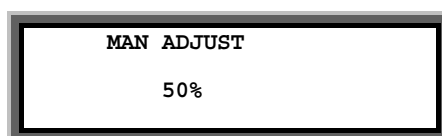

In the example above irrigation programs will run for half their normal time.

**IMPORTANT:** Do not leave the percentage value at 0%. No irrigation will run.

## Hours and Minutes (Option 12)

For program time in hours and minutes rather than minutes and seconds set Option 17 to '1'.

## Automatic Start disable (Option 13)

Option 13 allows all automatic starts to be disabled by pressing the **Select** key when on the Time page. When automatic starts are active the controller will display the following:-

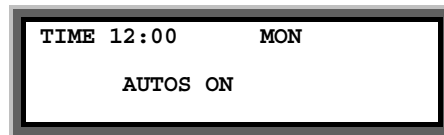

If the **Select** key is pressed the controller will then display the following and all automatic starts will be disabled until the **Select** key is pressed again.

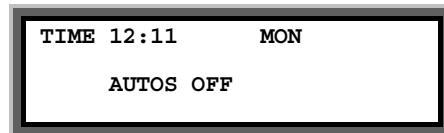

## Enable and Display Advanced Options (Option 15)

If you wish to use the 'Advanced Options' set Option 15 to 1. Advanced Options are Options 16 onwards.

With option 15 set at 0 you will not be able to access the Advanced Options. Furthermore, the controller will ignore the value of all Advanced Options if Option 15 is 0.

HERON ELECTRIC COMPANY LTD

# Advanced Options Manual

MCI-100S TWO WIRE DECODER CONTROLLER

---

This manual refers to MCI Controllers using software version 74A1.

Doc Ref MCI100 74A1 ADVANCED

April 2001

## 13 Changing Configuration Options

This manual describes the advanced features of the controller. Advanced features are activated by changing the configuration options of your controller. To access the configuration options: press and hold down the **"Manual Advance" for 10 seconds**.

The advanced options are from Option 16 onwards. The basic Options (1-15) are listed here for completeness.

### Basic Options 1-15.

Option	Function - See Basic Manual for detailed description	Default Value	Allowed Values
1	Set number of valves.	48	1-99
2	Set number of Daily automatic starts.	0	30
3	Set number of Weekly automatic starts.	3	32
4	The number of irrigation programs	1	16
5	Set pump pressurisation time in minutes.	0	59
6	Set pump pressurisation time in seconds.	2	59
7	Rain sensor connected and number of historical rain days	0	4
8	The Day of the week (1 = Monday, 2 = Tuesday)	1-7	1-7
9	Controller does a permanent Stop instead of Freeze	0	0/1
10	Display Low Tank instead of Freeze or Stop	0	0/1
11	Use Percentage Up and Down	0	0/1
12	Valve times in Hours and Minutes	0	0/1
13	Use 'Disable Automatic Starts' facility	0	0/1
14	Spare	0	0/1
15	DISPLAY ADVANCED OPTIONS (OPTIONS 16 TO 72)	0	0/1

**IMPORTANT: To use Advanced Options, Option 15 must be set to 1.**

**Advanced Options 16-72.**

<b>Option</b>	<b>Function</b>	<b>Default Value</b>	<b>Allowed Values</b>
16	Allocate 'I1' input to a specific program	1	1-16
17	Over Load 1 threshold	8	1-20
18	Allocate the number of cycling programs	0	0/1
19	Maximum number of automatic started programs to run together	0	0-8
20	Maximum number of cycling programs to run together	0	0/1
21	Allow only one program to run whether 'normal' or 'cycling'	1	0/1
23	Programs to Run Synchronously	0	0/1
24	Use wean facility	0	0/1
29	Cycling programs to take priority over all automatic started programs	0	0/1
30	Program 1 will take priority	0	0/1
32	Manually start multiple programs	0	0/1
33	Display 2 <sup>nd</sup> time page	0	0/1
34	Use variable period automatic starts	0	0/1
35	Percentage adjust on programs 7-16 only	0	0/1
38	Irrigate on volume (Use Input 2 for flow sensor)	0	0/1
39	Cycling uses Remote Start Input	0	0/1
41	Two cable drivers	0	0/1
42	Valve names use a letter suffix	0	0/1
44	Engineering Only-Put Controller in configuration mode	0	0/1
45	Engineering Only-Put controller in test mode	0	0/1
49	Engineering Only-Engineering Only-Display optical errors	0	0/1
50	Engineering Only-	0	0/1
51	Engineering Only-Display current	0	0/1
52	Engineering Only-Display current accurately	0	0/1
55	Controller address – PC option	0	1-20
56	Delay between valves	0	0- 99
57	Keypad security	0	0- 99
70	No flow protection	0	0- 99
71	Number of Automatic Start programs to back-up	0	0-16
72	Number of Continual Cycling programs to back-up	0	0- 16

## 14 Assigning Valves and Names and Customising Irrigation Programs

This section describes how to :-

- assign names to valves
- how to customise your irrigation programs to use named valves
- set whether valves run in parallel in a program
- change the order in which valves run in a program

### Assigning Valve Names

Valves can be named individually rather than using VALVE 1, VALVE 2 etc.

Your controller is supplied with a number of standard name prefixes to which you can add a number and a letter. The standard prefixes are :-

VALVE, GREEN, TEE, FWAY, APRCH

You can create valve names such as Green 01, Tee 01a, APRCH02a etc. Additional prefixes can be added with the aid of a PC and Ground Control Software.

The valve name is assigned on the serial number page. Therefore, to change a valve name go into the serial number pages. For example if you wish to change the name of 'VALVE 1' to 'GREEN 10' proceed as follows:-

Go to the Serial Number page for Valve 1 as shown below (see User and Installation manual)

EDIT S/N 001	EXIT
VALVE 1	02345

- Move the cursor over 'VALVE '
- Now press 'Select' to display GREEN.
- Press '>' to move the cursor over the valve number (1 in the above example)
- Enter '10' for GREEN 10.
- Now Press '>' to enter the serial number of the valve

In the example below a valve called 'GREEN 10' has been defined with a serial number of 2334.

EDIT S/N 001	EXIT
GREEN 10	02334

**IMPORTANT** The **Name Reference Number** is shown on the top line (number 001 in the above example). You will need to use the Name Reference Number to set up your irrigation programs as described in the next section

Furthermore, any valve errors are reported using the Name Reference Number.

## Valves Names Use a Letter (OPTION 42)

If you need more than one valve with the name GREEN10, you can add a letter so you can have names such as:-

GREEN10a  
GREEN10b  
GREEN10c

To enable this you must set Option 42 to 1

## Manual Valve Start With Named Valves

The operation of a manual valve start will change with named valves as you will need to select the correct name. For example if you wish to manually start 'GREEN10a' proceed as follows:-

To start a valve:-

- Press '**Start**'
- Press ">" to move the flashing arrow to point at "VALVE"
- Press "**Select**" and the page below is shown.
- Now press "**Select**" to display the correct valve name, ie **GREEN**
- Now enter the valve number.
- Press ">" to move the flashing arrow to the right
- Now enter the optional letter ie 'a' by repeatedly pressing '**Select**'.
- Press ">" and enter the run time for the valve.

In the example below GREEN10a as been set to run for 2 minutes.

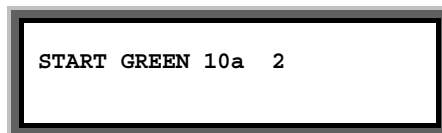

```
START GREEN 10a 2
```

Now press "**Select**" to start this valve and the following page is displayed.



```
TIME 12:11  
GREEN 10a 1:59
```

## Customising Programs

You only need to do this if:-

- you wish to vary the number of valves that run in parallel.
- you wish to vary the order in which valves run in the program
- you wish to change valve names

First you need to select the configuration mode by setting **Option 44 to 1**. **When you have finished you should now set Option 44 back to 0**. This prevents the sequence number and the valve names being changed.

Now you need to enter the program, you wish to customise. Press ">" to display the 'Enter Program Page' as shown below.

```
ENTER PROG 1
```

Now press **Select** to edit program 1 and the first page of Program 1 will be displayed. If the controller is new it will be the default configuration as shown below.

```
1 VALVE 01 00:00 EX
1 VALVE 02 00:00
1 VALVE 03 00:00
1 VALVE 04 00:00
```

## Changing the Zone Number

In the example above, there are four valves displayed called VALVE 01 , VALVE 02 VALVE 03 and VALVE 04.

The number on the left is the irrigation zone number for the valve. They are all set to 1 so all valves are in the same zone (zone1). As they are in the same zone NO valves will run together.

If, for example, you wanted VALVE 01 and VALVE 02 to run together you would need to assign them to different irrigation zones, as follows:-

```
1 VALVE 01 00:00 EX
2 VALVE 02 00:00
1 VALVE 03 00:00
1 VALVE 04 00:00
```

To do this move the cursor over the zone number for VALVE 02 and change it to 2.

## Changing the Valve Order

If, for example, you wanted VALVE 04 to run before VALVE 03 then you would need to change the page to the following:-

1	VALVE 01	00:00	EX
1	VALVE 02	00:00	
1	VALVE 04	00:00	
1	VALVE 03	00:00	

Now VALVE 04 appears before VALVE 03 in the list so VALVE 04 will run first.

To do this move the cursor so it is over VALVE 03 and the page will automatically ask you to enter the Name Reference Number. In the example below it is currently at 003 which is the reference for VALVE 03.

1	VALVE 01	00:00	EX
1	VALVE 02	00:00	
1	NAME 003		
1	VALVE 03	00:00	

Now change **Name Reference Number** to 004 which will be the **Name Reference Number** for VALVE 04.as shown below.

1	VALVE 01	00:00	EX
1	VALVE 02	00:00	
1	NAME 004		
1	VALVE 03	00:00	

Now press '>' and VALVE 04 will be the third valve in the program.

## Changing the Valve Name (if you are using named valves)

If you are using named valves you can change the valve name in the same way as changing the valve order. For example, if we want to add the name GREEN 10 to the first position in the program above proceed as follows:-

Enter Program 1 and move the cursor over VALVE 01 and the page will automatically display NAME 001 as shown below :-

1	NAME 001	00:00	EX
1	VALVE 02	00:00	
1	VALVE 03	00:00	
1	VALVE 04	00:00	

Now enter the new **Name Reference Number** . The **Name Reference Number** is shown on the Serial Number Page for this valve. For example, if the **Name Reference Number** is '007' for GREEN10 type in 7 as shown below.

1	NAME 007	00:00	EX
1	VALVE 02	00:00	
1	VALVE 03	00:00	
1	VALVE 04	00:00	

Now press '>' and the page will show GREEN10 in the first position.

1	GREEN 10	00:00	EX
1	VALVE 02	00:00	
1	VALVE 03	00:00	
1	VALVE 04	00:00	

**IMPORTANT** When you have finished you should now set the Configuration Option 44 back to 0.

## 15 Irrigation Program Options

### Maximum Number of Automatically Started Programs to Run Together (Option 19)

This specifies the maximum number of automatically started irrigation programs that can run at the same time. If this option is set to '0', only one irrigation program can run at any time. Setting this option to 2 will allow 2 irrigation programs to run at the same time.

**Note:** A maximum of 4 irrigation programs can run at any time. This includes automatically started AND continually cycling programs. See option 20 below.

### Display Second Run Time page (Option 33)

If 3 or 4 irrigation programs are running at the same, this option will allow you to view a second time page for the third and fourth programs. By setting option 33 to '1' the second run time page will be displayed. Default is '0'.

### Allocate Remote Start input to a Program (Option 16)

The Remote Start Input can be assigned to initiate any irrigation program. Enter the number of the irrigation program you want it to initiate. If this option is not set, the Remote Start Input will trigger irrigation program 1 by default.

### Program 1 will Take Priority (Option 30)

This allows program 1 to take priority over any other automatically started irrigation programs. If you need his facility set Option 30 to '1'. Default is '0'.

With Option 30 set, if a program is running, and program 1 wishes to start, it will cut-in and run. The halted irrigation program will continue from where it was stopped, once program 1 has completed.

**Note:** If option 29 has been set then any the continually cycling program will have priority running over irrigation program 1.

### Delay Between Valves (Option 56)

A delay between the operation of the valves within an irrigation program can be introduced using this option. The delay can be set from 1 to 99 seconds. Enter the number of seconds delay required. The delay will apply to all irrigation programs.

### Rain Sensor and Manual Percentage to Reduce Watering for Programs 7-16 (Option 35)

The watering times of valves within programs can be reduced by either the connection of a rain sensor or by entering a manual watering reduction percentage. If option 35 is set, these two methods of reducing watering times, is limited to irrigation programs 7 to 16 only.

Set option 35 to '1' to activate this option. Default is 0.

## 16 Automatic Start Options

The controller allows daily and weekly automatic starts to be set. You can specify the number of each type of automatic starts you wish to use. You can specify up to **30 daily** automatic starts and up to **32 weekly** automatic starts, see 'Basic Manual'.

You also have the option to specify variable period automatic starts instead of weekly automatic starts. For example, you can specify that one program starts every three days and another program starts every four days.

### Number Automatically Started Programs to Back-Up (Option 71)

If an 'Automatically Started' program cannot run because another program is running the controller can remember that a program tried to start. The controller will run the program when the other program(s) have finished. Option 71 controls the number of automatic starts that the controller will remember. Values between 0 and 16 are allowed.

Set Option 71 to 0 if you do not want any Automatic Starts remembered. Set Option 71 to '1' for one start to be remembered, set to 2 for 2 starts etc. Default is 0.

### Variable Period Automatic Starts (Option 34)

Weekly automatic starts only allow programs to be started on specific days. If you need programs to start at differing intervals set option 34 to '1' to allow 'variable period' automatic starts. The maximum interval for a variable period automatic start is 9 days.

When option 34 is set to '1' the Weekly Automatic Start pages change to the following format.

```
AUTO4          EXIT
                TODAY=1ST
OFF  1ST DAY AT 0:00
```

Setting a variable automatic start is very similar to a weekly automatic start except that you must specify **what day** it is today for **each automatic start**. This is described in the following example.

**Example:** Program 1 to start every 2 days at 12:00 starting tomorrow.

Program 2 to start every 3<sup>rd</sup> day at 09:00 starting today.

For program 1 set a variable automatic start page, using the cursor back, cursor forward and the number keys, as shown below.

```
AUTO4          EXIT
                TODAY=1ST
PRG1  2ND DAY AT 12:00
```

On day 1, the 'TODAY' equals count will be set as "1<sup>st</sup>". Program 1 will not start.

On day 2, the 'TODAY' equals count will automatically change to "2<sup>nd</sup>". Program 1 will run.

For program 2 press the '>' button to move to the next variable automatic start and change the page to the one shown below.

```
AUTO5          EXIT
                TODAY=1ST
PRG2 3rd Day AT 09:00
```

Program 2 is set to start on the 3rd day. The problem is that the 'TODAY' equals count will equal the 3rd day in two days time. We want Program 2 to start today and not in 2 days time. To make this happen we must manually set the 'TODAY' equals count to the 3rd day by using the '>' button to position the cursor on the 1<sup>st</sup> and pressing the '3' button.

```
AUTO6                EXIT
                    TODAY=3rd
PRG2 3rd Day AT    09:00
```

On day 1, the 'TODAY' equals count will be set as "3rd". Program 2 will run.

On day 2, the 'TODAY' equals count will automatically change to "1st". Program 2 will not start etc.

On day 3, the 'TODAY' equals count will automatically change to "2nd". Program 2 will not start.

On day 4, the 'TODAY' equals count will automatically change to "3rd". Program 2 will run.

## 17 Continual Cycling Option

### Use A Continual Cycling Program (Option 18)

This option allows irrigation programs to continuously cycle. Programs continually cycle between a specified start and stop time, with a programmable delay between cycles. This is normally used for misting or propagation applications.

Set option 18 to '1' for program 1 to be a continually cycling program.

#### Setting Up Continual Cycling

An extra page will be displayed after the Time Page, as shown below. This page allows you to:

Specify the start and stop times for the continual cycling period

Set the delay period (in hours and minutes) between each cycle

Disable / Enable the continual cycling program.

Now Press "**Select**" to enter the start and stop times for continual cycling and the delay period between cycles.

```
CYCLE PROG 1  
  
CYCLE NEVER  
WAIT 0:00
```

In the example below, program 1 has been set to continually cycle from 6:00 hours to 21:30 hours, with a 20 minute delay between each cycle.

```
CYCLE PROG 1  
  
CYCLE 06:00 > 21:30  
WAIT 0:20      NEXT 13:30
```

The time that the next cycle will begin is automatically calculated and displayed if the real time is within the cycling range. In the example above, the next continual cycle of program 1 will begin at 13:30 hours.

#### Disabling Continual Cycling

You can disable the continual cycling program by pressing the "**Select**" button when the continual cycling page is displayed.

```
CYCLE PROG 1  
  
CYCLE NEVER  
WAIT 0:00
```

To re-enable continual cycling press the "**Select**" button again. The start times will be redisplayed.

```
CYCLE PROG 1  
  
CYCLE 06:00 > 21:30  
WAIT 0:20      NEXT 13:30
```

## Other Options You May Want to Set

### Number of Continual Cycling Programs to Back-Up (Option 72)

If a 'Continual Cycling' program cannot run because another program is running the controller can remember that a program tried to start. The controller will run the program when the other program(s) have finished. Option 72 controls the number of cycling starts that the controller will remember. Values between 0 and 16 are allowed.

Set Option 72 to 0 if you do not want any cycling starts remembered. Set Option 72 to '1' for one start to be remembered, set to 2 for 2 starts etc. Default is 0.

### Allow Only One Program to Run whether 'Normal' or 'Cycling' (Option 21)

If option 21 is set to '1', only one irrigation program will ever run at any time. Option 21 overrides options 19 and 20 i.e. specifying how many automatically started and continually cycling programs can run at the same time. Default is '1'.

**Note:** If you want either automatically started or continually cycling irrigation programs to run at the same time, then you **must** set option 21 to '0'.

### Cycling Uses Input 2 (I2) (Option 39)

You can use a sensor to control any of the continual cycling programs. Connect the sensor to Input 2 (I2) and set option 39 to '1'.

If the sensor on Input 2 is triggered, the continual cycling delay time is automatically reduced to zero until the trigger is removed. You need to set the delay time to a large value so under normal operation the sensor will initiate the irrigation rather than the delay timer expiring of its own accord.

### Cycling Programs to take Priority Over Auto Start Programs (Option 29)

This option allows any of the continually cycling programs to take priority over any automatically started irrigation program.

With this option set, if an automatically started irrigation program is running, the continually cycling program will cut-in and run. The halted automatically started irrigation program will then continue from where it was stopped, once the cycling program has completed.

If you want this facility set option 29 to '1'. Default is '0'.

## 18 Wean Facility (Option 24)

The wean facility allows Program 2 to be operated half as many times as Program 1, see table below. Programs 2 is automatically triggered after Program 1 finishes.

Irrigation Initiated	Program 1	Program 2
First Time	X	
Second Time	X	X
Third Time	X	
Fourth Time	X	X
Fifth Time	X	
Sixth Time	X	X
Seventh Time	X	
Eighth Time	X	X
Ninth Time	X	

:

## 19 Installation Options

### No Flow Protection (Option 70)

With an appropriate sensor is connected to the 'I1' input, either a lack of water flow or pressure will result in an alarm condition and the halting of the irrigation. In this case, a closed contact equates to no fault.

Option 70 allows you to specify the time, in seconds, to elapse whilst the first valve in the irrigation program is running, before the controller attempts to detect this condition.

### Keypad Security (Option 57)

If you require a security code to be entered before the controller can be used , then set option 57.

Set option 57 to any number from '01' to '99'. This number will become the third and fourth digits of the security code. The first and second digits of the security code will be '57'.

For example, if option 57 has been set to '15', then the security code "5715" must be entered when ever the controller is operated.

The user must enter the security code if the keypad is not used for three minutes