

USER AND INSTALLATION MANUAL MCI-100S

Heron Electric Company Ltd

WARNING: This unit should be installed by a competent electrician.
Input Supply - See Inside controller Output Voltage - **30V AC**

May 2000
Document Reference

1. The MCI-100S

The MCI-100S is a sequential irrigation controller which operates 24V AC solenoid valves via "decoders". Up to 100 decoders can be connected to the controller via a common 2-core cable.

Testing The Controller

The controller can be tested by installing the 4 C Size Batteries and then switching on the LCD display. The LCD display is switched on by pressing and holding down the **Set All** key for 2 seconds. You can do this without the mains power connected.

Care of YOUR CONTROLLER

Never use sharp objects to press the buttons on your controller and avoid pressing the buttons with your finger nails.

Always ensure the lid screws are screwed down tight so the inside of the controller is kept dry and to reduce exposure to high humidity.

What You Should Read

If your controller is already installed you can go to Section 3.

2. INSTALLATION

WARNING Installation should be carried out by a Competent Electrician.

Mounting the MCI-100S Controller

The controller should be mounted on a wall using four screws, one screw through each corner lid bolt hole. Warning: Additional holes should not be drilled through the controller casing.

Connecting Mains Supply

IMPORTANT SAFETY CHECK. Check that the mains supply voltage IS the SAME AS the VOLTAGE OF the CONTROLLER. The controller voltage is displayed on the inside the controller casing. The mains supply should be fused with a 3 amp fuse and be connected via a Residual Current Circuit Breaker as per any equipment used in damp conditions. Connect the mains supply to the three terminals as shown in Fig 1, L to Live, N to Neutral, E to Earth.

Connecting Decoders

Connect decoders as per diagram Fig 1.

It is recommended that a 2-core water proof cable eg. polythene cable or similar, is used to connect the decoders. The cable must **NOT** be installed near mains voltage cables. Interference may result from externally induced voltages. All cable joints must be sealed to minimise water ingress.

The controller gives out 30VAC to power 24VAC solenoids. This larger voltage allows for voltage drop in the 2 core cable. If you are connecting solenoids close to the controller (less than 200m) there will be little voltage drop and you should check that the solenoids are capable of withstanding a voltage as high as 30VAC.

Two output decoders

Two output decoders have two serial numbers and two outputs.

	1st Serial No.	2nd Serial No.
Serial No. controls decoder output on	YELLOW	WHITE wire

The return wire from the solenoid valves are wired to either of the red wires.

Cable Earth Points

Cable earth points should be wired to the cable with earthing rods as also shown in Fig 2. A minimum of 3 should be installed for a looped cable and a minimum of 2 for a straight cable. Additional cable earthing points should be wired every 1000 m if necessary. Failure to wire these earthing points will make the controller liable to surges caused by lightning which may causes serious damage.

Battery Supply

The processor board is powered from 4xC size alkaline batteries. These batteries will last between 2 to 4 years. When the batteries run low the controller will display "LOW BATTERY".

Pump Start (24VAC)

The pump start output is across the terminals marked 'Pump'. This output is rated at 24VAC 0.5A.

Infra Red Link

The processor board (mounted in the lid of the controller) is completely isolated from the 2-wire line driver. The processor board communicates with the line driver via an optical link. Nothing should be placed in the way of this link or in the isolation zone as shown on Fig 1.

Note: Two red wires are internally connected in the decoder

Fig 1 Output Wiring

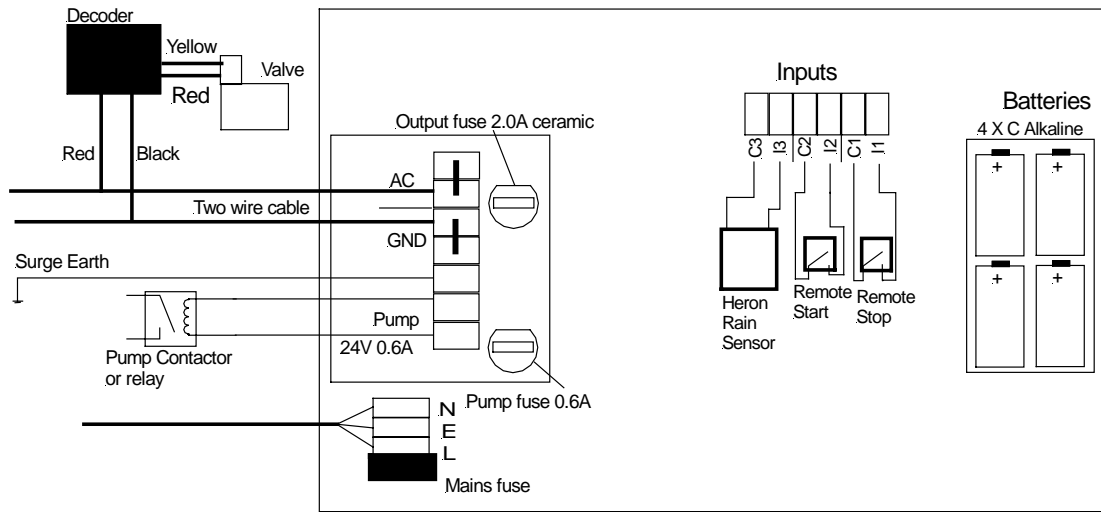

Warranty void if wrong fuses fitted !

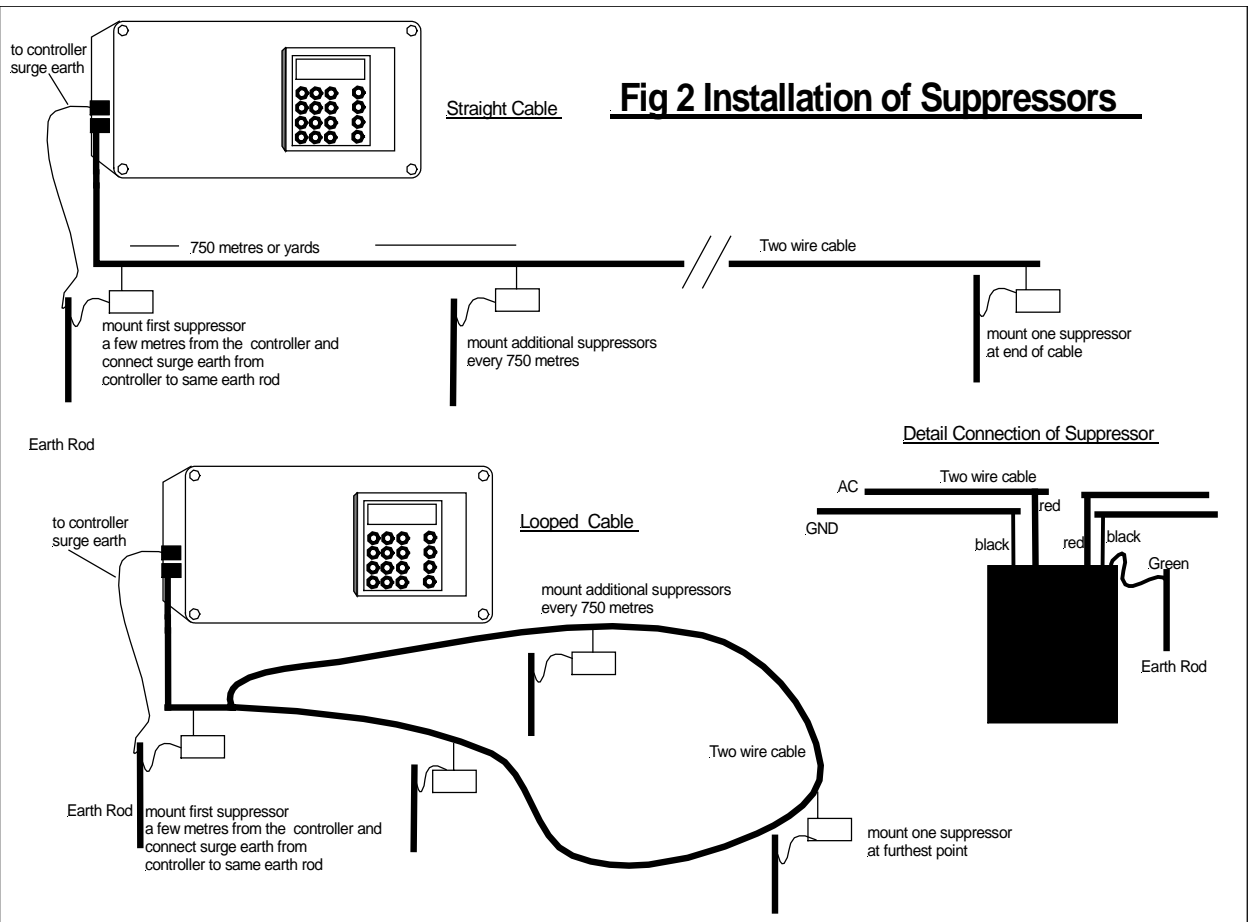

Setting Decoder Serial Numbers

If you are installing the system you need to set the Decoder Serial Number of each irrigation valve .

The decoder serial number is shown on the side of each decoder. Any decoder serial number can be assigned to any valve. For example, if you have a decoder with serial number 02345 and you wish this to be valve 1 you must assign 02345 to valve 1. Proceed as follows

Press '>' until the following page is displayed

```
ENTER S/N
```

Press '**Select**' and the following page will be displayed

```
EDIT S/N          EXIT
VALVE 1  02345
```

Now enter the required Serial Number for valve 1, for example to 02345.

Press '>' to enter the serial numbers of other valves

Move the cursor over the EXIT position and press **Select** when you have finished

Assigning Cable Driver Number (Two-Cable Drivers Controllers Only)

If your controller has two cable drivers you need to define which cable the decoder and valve are attached to.

A controller with two cable drivers will show the cable number for each valve after the serial number. In the example below it is set to 1 which is the default value. To change this number press '>' after you have entered the serial number. Then press 1 or 2 for cable driver 1 or 2 respectively.

```
EDIT S/N  001          EXIT
VALVE 1  02345    1
```

NOTE: If the cable number is not displayed you should set Option 46 to 1, see advanced manual.

1. USING THE CONTROLLER

The LCD display will switch off after 3 minutes to save battery power . To switch the LCD display back on press and hold down the **Set All** key for 2 seconds.

Your controller is supplied in its simplest configuration. How to change this configuration is described in the Advanced Feature Manual. The description given in this section assumes the controller is in its simplest configuration. When the controller is switched on, the Time page is displayed as shown below.

```
TIME 12:11
VALVES OFF
```

Other pages are displayed by pressing the cursor forward key ">" as described in the next section.

Basic Operation Pages

The Time Page

```
TIME 12:11
VALVES OFF
```

From the time page pressing ">" will show

The 'Enter Programme' Menu Page

```
ENTER PROG ?
```

Now pressing ">" will show

```
ENTER AUTO STARTS
```

The 'Enter Automatic Start ' Menu Page

Now pressing ">" will show

The 'Enter Serial Number Menu' Page

```
ENTER S/N
```

Now pressing '>' will return you to the Time Page at the top.

2. Setting up an Irrigation Program

Press ">" to display the 'Enter Programme Page' as shown below.

```
ENTER PROG 1?
```

Now press **Select** to edit programme 1 and the following page will be displayed.

```
          PROG 1
VALVE          EXIT
 1             2             3
10:30         00:00         00:00
```

The time in minutes and seconds can now be entered for each valve in the programme. In the example above valve 1 has been set to run for 10 minutes 30 seconds. Now move the cursor forward using the ">" key and enter the remaining required valve run times.

To return to the 'Time Page' press '>' until the cursor is positioned over EXIT. press **Select**.

To return to the 'Time Page' and the two menu pages move the cursor to 'EXIT' by pressing '>'. When the cursor is over EXIT press **Select**.

3. Setting Automatic Start Times

Press ">" to display the 'Enter Automatic Start' Page as shown below.

```
ENTER AUTO STARTS
```

Press **Select** and the following page will be displayed.

```
          AUTO
1         2         3     EXIT
PRG1     OFF      OFF
10:30    00:00    00:00
```

Enter the start time for each required automatic start . Now you must assign the start time to a particular irrigation program. With the cursor positioned under the automatic start time press **Select** until the correct program is displayed. In the example above Program 1 is set to start at 10:30.

If you wish to disable an automatic start, position the cursor under the automatic start and press **Select** until 'OFF' is displayed. In the example above all other automatic starts are off.

Note: Any automatic start can be set to start any irrigation program.

To return to the 'Time Page' move the cursor to 'EXIT' by pressing '>'. When the cursor is over EXIT press **'Select'**.

4. MANUAL START/STOPS

Manual Start

The pump, an individual valve or an irrigation program, can be started manually by pressing "**Start/Stop**". When "**Start/Stop**" is pressed the display below will be shown.

```
START >PUMP VALVE
        PROG
```

Pump Start

With the flashing arrow pointing at 'PUMP' press "**Select**" to start the pump. The display below is shown.

```
TIME 12:11
        PUMP ON
```

Valve Start

To start a valve:-

Press ">" to move the flashing arrow to point at "VALVE"

Press "**Select**" and the page below is shown.

```
START VALVE 10 2
```

Now Enter the number of the valve to be started

Press ">" and enter the run time for the valve.

In the example above, the valve 10 has been set to run for 2 minutes. Now press "**Select**" to start this valve and the following page is displayed.

```
TIME 12:11
        VALVE 10 1:59
```

Program Start

To start an irrigation program

Press ">" to move the flashing arrow to point at PROG.

Press **Select** and then enter the number of the program to be started.

Press "**Select**" to start the irrigation program

The following page will be displayed.

```
TIME 12:11
PROG 1 VALVE 1 10:29
```

Manual Stop

Pressing "**Start/Stop**" at any time when a program, valve or pump is running will stop the program pump or valve immediately.

5. OTHER KEYS

Cursor back key <

The cursor back key "<" is used to go backwards through the pages.

Manual Advance

When the irrigation program is running, pressing "**Manual Advance**" will move a program onto the next valve in the program. This can be used for testing.

Set All

The '**Set All**' key is a quick method of setting a range of valves to the same time when setting up an irrigation program. Pressing "**Set All**" will display the following page. The range of valves and the required run time can be entered on this page.

The range of valves is entered when editing an irrigation program.

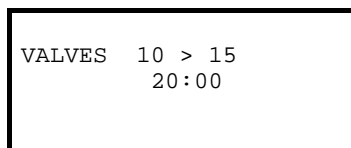

```
VALVES 10 > 15
        20:00
```

In the example shown above, valves 10 to 15 have all been set to run for 20 minutes each.

Pressing "**Set All**" again will return you to the normal irrigation program page.

6. FAULT DETECTION

If a fault occurs whilst the controller is running a watering program, for example a cable breaks, then the following display is shown.

```

TIME 12:11

          FAULT
    
```

The nature of the fault is displayed by pressing '>' to view the 'Fault Page'. An example fault page is shown below.

```

          FAULT
V12 O/L 6
V16 O/L 6
    
```

IMPORTANT: In the example above the faults are on **valve numbers 12 and 16**.

The following eight fault types can be detected:-

	Fault	Controller Displays
1	2 core cable line loading not OK	CAB O/L 1
2	Remote Short on 2 core cable (more than 1.6 amps)	CAB O/L 2
3	Direct Short on main 2 core cable (more than 6 amps)	CAB O/L 3
4	Current over load when valves running (more than 1.6 amps)	CAB O/L 4
5	Large Current overload when valves running (more than 6 amps)	CAB O/L 5
6	Decoder output overload (more than 0.6 Amps from decoder)	Vn O/L 1
7	No acknowledgement from decoder when switching on	Vn DECO (n=valve no.)
8	No acknowledgement from decoder when switching off	Vn OFF (n=valve no.)

In the example above the fault page indicates that current overload fault number '6' has occurred on both valves number 12 and 16

The controller takes the following action depending upon the fault:-

Faults 1 to 3

If faults '1' to '3' occur all irrigation programmes will be immediately stopped as it is impossible for the controller to communicate with decoders.

Faults 4 to 6

If faults 4 to 6 occur the current and subsequent irrigation programmes will continue as normal. However if a total of six occurrences of faults '4' to '6' are reported all irrigation programmes will be suspended .

Faults 7 and 8

If a decoder fault is reported, the current and subsequent irrigation programmes will continue as normal. However if a total of six occurrences of the faults are reported all irrigation programmes will be suspended .

Clearing Fault Conditions

The fault page is cleared by manually starting and stopping an irrigation program.

POWER FAULTS

The controller will display 'POWER OFF' when there is no mains power or when the optical link is not working correctly.

The controller will display 'LOW BATTERY' when the battery power is low. Replace the 4 x C size alkaline batteries.

1. MISCELLANEOUS

changing the time

Press ">" until the time page is displayed as shown below. Now press and hold down **"Select"** for five seconds and the cursor will appear as shown below. Now change the Hours and Minutes using the number keys. When you have set the time press **"Select"** again for five seconds until the flashing cursor disappears.

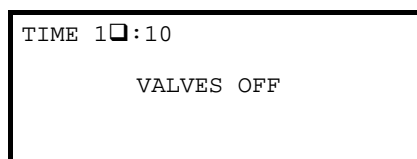

RESETTING THE CONTROLLER

The controller is reset by disconnecting the battery connection for 5 seconds. The line driver can be reset by disconnecting the mains power for at least 5 seconds and then switching it back on again.

2. ADDITIONAL INPUTS AND OUTPUTS

Remote Start

The remote start input is across "I2" and "C2". Joining these terminals will start program 1. The terminals have to be connected for only a short period (1 second), to activate the program. If the contacts are left shorted program 1 will continually cycle.

Remote Stop

The remote stop input is across "I1" and "C1". Joining these inputs halts the irrigation programmes. The programmes will continue once the short is removed. This input may be connected to a float switch in the water reservoir so that the watering sequence is halted if the water level is low.

Rain Input

The rain input is across "I3" and "C3". Only a Heron rain sensor can be connected to these terminals.

HERON ELECTRIC COMPANY LTD

Advanced Features Manual

MCI-100S

NOTE: This manual refers to MCI controllers using software version 7221E.

Document Reference MCI100 7221E ADVANCED

1. ADVANCED FEATURES

This section describes the more advanced features of the controller. If you wish to use these features you will need to set the required Option. How to set Options is described in section 9.0.

The following features are described in this section:-

- Week Day Programming
- Continual Cycling
- Percentage Up and Down
- Rain Sensor
- Watering By Volume
- Valve Programmes using 'Greens' and 'Teas'

2. Week Day Programming

(Option 15 must be set to 1)

When weekly programming is selected the automatic start page will change to allow you to select whether the automatic start should start a programme on:-

- a particular day of the week
- an even or odd day of the week
- daily

To view and change an automatic start go to the 'Enter Automatic Start' page and press **'Select'**. Three automatic starts will be displayed as shown below.

	AUTO STARTS	EXIT
<input type="checkbox"/> FF	OFF	OFF
PRG1	PRG1	PRG1
10:30	00:00	00:00

To change the day of the week for an automatic start, move the cursor to the position marked with in the example above and press **'Select'** until the correct day is displayed.

Now move the cursor down a line by pressing '>' as shown below. Now press **'Select'** until the correct programme is displayed,

	AUTO STARTS	EXIT
TUE	OFF	OFF
<input type="checkbox"/> RG2	PRG1	PRG1
10:30	00:00	00:00

Now move the cursor down a line again as shown below and enter the time of the automatic start.

	AUTO STARTS	EXIT
TUE	OFF	OFF
PRG2	PRG1	PRG1
1 <input type="checkbox"/> :30	00:00	00:00

In the example below Programme 2 will come on every Tuesday at 10:30

	AUTO STARTS	EXIT
TUE	OFF	OFF
PRG2	PRG1	PRG1
10:30	00:00	00:00

Other automatic starts are set in the same way. If you need to switch off an automatic start move the cursor over the day and press select until 'OFF' is displayed.

When week day programming is first selected you must set the controller to the correct day of the week. To do this first EXIT to the Time Page. The time page is shown below.

```
TIME 12:11      DAY1 MON
      VALVES OFF
```

Now proceed as follows:-

Press and hold down **Select**. The cursor will start flashing.

Press **Manual Advance** and the day of the week shown in the top right hand corner will change.

Press **Manual Advance** until the correct day is displayed (remember it is a 14 day clock).

Press and hold down **Select** again until the cursor stops flashing.

3. Percentage Up and Down

(Option 11 must be set to 1)

Percentage Up and Down allows all irrigation run times to be temporarily adjusted by a specified percentage (0%-600%). To change the percentage value proceed as follows.

Exit to the Time Page

Press '>' until the percentage Up and Down page is displayed..

```
SET PROGS 1-28
          00%
```

Now enter the required percentage value. 100% is the normal value.

IMPORTANT: Do not leave the percentage value at 0% as the irrigation will not work.

To return to the Time Page press '>' until the Time Page is shown

Limitations to Use

This facility will not work with volume.

This facility is not recommended with valve times less than 15 seconds.

4. Continual Cycling

(Option 12 must be set to 1)

Continual cycling allows Programme 1 to be continuously cycled with a programmable delay at the end of the programme. This is normally used for misting/cooling applications. The time of day through which continuous cycling is active can be specified. For example, continual cycling can be disabled at night.

Setting Up Continuous Cycling

With Option 12 set to 1, the continual cycling page will be displayed. To view this page proceed as follows:-

Exit to the Time Page

Press '>' until the Continual Cycling Page is displayed.

The page allows you to:-

- switch cycling On and Off using '**Select**'
 - set the start and stop times for continual cycling period
- set the delay period (in hours & minutes) between each cycle

CYCLING OFF		
START	STOP	DELAY
00:00	00:00	00:00

In the example below, continual cycling has been set to run from 9:00 to 20:00 hours, with a delay of 5 hours 30 minutes between each cycle.

CYCLING PROG1		
START	STOP	DELAY
09:00	20:00	05:30

To return to the Time Page press '>'

Other Options you may want to set

If you are using a sensor to control continual cycling via the remote start input you need to set Option 20. This sets the remote start input to control continual cycling.

If you are running a main watering programme with continual cycling you may want to set Option 18 to give the continual cycling programme priority over other irrigation programmes.

5. Rain Sensor

(Option 10 must be set to 1)

The Heron rain sensor allows the irrigation times to be reduced depending on the amount of rain that has fallen over the last 24 hours (this is a rolling count accurate to six hours). Three trip points can be set.

Using the Rain Sensor

When Option 10 is set to 1 the rain page is displayed. To view the rain page proceed as follows:-

Exit to the Time Page

Press ">" until the rain page is displayed as shown below.

The quantity of rain that has fallen in the last 24 hours is shown on the top line of the page.

RAIN 2mm			
%TIME	60	30	00
TRIP	2	4	9

On the rain page you can set three trip points. The trip points are set in millimetres of rain fall. When these trip points are met irrigation programmes will run for either 60% of their normal time, 30% of their normal time or 0% of their normal time. To set a trip point move the cursor under the appropriate percentage (60%, 30% or 0%) and enter a number. In the example above trip points have been set at 2 mm, 4 mm and 9 mm.

Testing the Rain Sensor

The rain sensor can be tested by pressing the spoon down inside the rain sensor. Now press ">" or '<' until the rain page is displayed and you will notice that the rain fall will have incremented by 1 mm. If you press the spoon enough times so that a trip level is reached you will see a reduction in the irrigation watering programmes. However, you must wait one minute before you start the irrigation programme after your tests.

To return to the Time Page press '>' .

6. Irrigation Based on Volume

(Option 19 must be set to 1)

The volume facility will allow you to set programmes in litres of water rather than in time.

Irrigation programmes are set up in exactly the same way except a volume is entered instead of a time.

If you are using a flow meter that gives one pulse out per litre of water then type in the actual value. If you are using a flow meter that gives one pulse out per 10 litres then type in one tenth of the required value.

In the example below, valve 1 is set for 11,000 litres and valve two for 5,000 litres with a flow meter giving one pulse per 10 litres

VALVE	PROG 1		EXIT
1	2	3	1100
0500	0000		

Flow Meter Failure

If the controller does not receive a pulse for 15 minutes it will stop the irrigation programme.

7. Valves Named as Greens and Tees

(Option 7 must be non zero)

Instead of programmes being displayed in terms of 'Valve 1', 'Valve 2' etc the controller can display programmes as 'Green 1', 'Green 2' etc and 'Tee 1', 'Tee 2'. This is used for Golf Course applications. As described in section 9, you should set Option 7 to the number of Greens you require and Option 8 to the number of Tees you require.

Now, when you enter an irrigation programme, for example programme 1, the following page will be displayed

GREEN	PROG 1		EXIT
1	2	3	0:00
0:00	0:00		

Valve times are set in exactly the same way the same way as before. The 'Tees' will be displayed after the Greens. Press '>' repeatedly until the Tees are displayed.

Manual Valve Start With Greens and Tees

Operation of a manual valve start is changed because you need to select the valve type (Green, Tee or Misc) you wish to start. For example if you wish to start Tee 03 for 10 minutes proceed as follows.

Press "**Start**" and the page below is shown.

Press ">" so the flashing arrow is pointing at VALVE

Press "**Select**" to select valve

START	>PUMP	VALVE
		PROG

The following page will be displayed

Press "**Select**" to change Green to Tee

Now enter the number of the valve to be started ie '3'

Press ">" and enter the run time ie 10 for the valve and press "**Select**"

START GREEN 01 TIME 01

8. Disabling all Automatic Starts

(Option 24 must be set to 1)

All automatic starts can be disabled by pressing '**Select**' on the Time Page. The following will be displayed:-

```
TIME 12:11  
  
VALVES OFF  
AUTO OFF
```

The automatic starts can be enabled again by pressing '**Select**' again. The following will be displayed:-

```
TIME 12:11  
  
VALVES OFF  
AUTO ON
```

If **Select** is pressed when a programme is running then the 'Auto On' or 'Auto Off' message will flash up for a short period.

9. SETTING OPTIONS

The following section describes the advanced features of the controller. For example, you can set up multiple programmes. To initiate any of these features you must press "**Manual Advance**" for five seconds to re-configure the controller. The following page will be displayed.

OPTIONS		
1	2	3
28	4	30

Now press ">" and enter a number under the required Option. In the page above Option's 1,2 and 3 have been set to 28, 4 and 30. When the required options have been set press ">" or "<" until the 'Time' page is shown.

Note: You irrigation installer or dealer may have already set up your controller for you.

Pump Pressurisation Time Minutes and Seconds (Option 2 and Option 3)

The pump pressurisation time can be set in Minutes and Seconds in Option 2 and 3 respectively . (Values between 0 and 60 are allowed).

Engineering Only (Option 4)

OL/1 threshold.

Number of Programmes (Option 6)

Option 6 sets the number of programmes you want to use. (Values between 1 and 28 are allowed). The controller will be simpler to use with a smaller number of programmes set.

Greens and Tees (Option 7 and 8)

Option 7 will allow valves to be named as GREENS, TEES and MISC. This is used for Golf course applications. You should set Option 7 to the number of Greens you require, for example '18'. Set Option 8 to the number of TEES you require, for example '36'. You must, however, round the number of Greens and Tees to the nearest three. The remainder of the valves will be named as MISC. To disable this facility set Option 7 to '0'. Default is '0'.

Number of Automatic Starts (Option 9)

Option 9 sets the number of automatic starts you want to use . Values between 1 and 60 are allowed. The controller will be simpler to use with a smaller number of automatic starts set.

Rain Sensor (Option 10)

The Heron rain sensor allows the irrigation programme to be reduced depending on the amount of rain that has fallen over the last 24 hours. Simply set Option 10 to 1 and connect the rain sensor as described below.

Connecting the Rain Sensor

Connect the two terminals inside the rain sensor to "I3" and "C3" . The terminals in the rain sensor are accessed by lifting off the lid and removing the screw at the side of the rain sensor.

Section 8 describes how to use the rain sensor.

Percentage Up and Down (Option 11)

Percentage Up and Down allows all irrigation run times to be temporarily adjusted by a specified percentage (0%-600%). To use this facility set Option 11 to 1. Section 8 describes how to use percentage up and down. Default is 0.

Continual Cycling (Option 12)

Continual cycling allows programme 1 to be continuously cycled with a programmable delay at the end of the programme. This is normally used for misting/cooling applications. Set Option 12 to '1' for continual cycling. Default is 0.

Display Serial Number Page (Option 13)

Option 13 enables the 'Serial Number' page. You need to enable the Serial Number page when decoder Serial Numbers are defined to valve numbers. Setting Option 13 to 1 will display the Serial Number Page. Setting it to '0' will not display the page. When the page is not displayed serial numbers cannot be accidentally changed. Default is 0.

Minutes or Hours (Option 14)

For programme times in minutes and seconds set Option '14' to 0. For programme time in hours and minutes set Option '14' to 1.

Day or Week Programming (Option 15)

For daily programming set Option '15' to 0, for weekly programming set Option '15' to 1.

Parallel Programmes (Option 17)

This allows programmes to be run in parallel. For parallel programmes set option 17 to 1, for sequential programme operation set Option 17 to 0. To make two programmes run in parallel, set two automatic starts to the same time of day.

For parallel programme operation the following page will be displayed when 2 programmes are running together. In the example below Programme 1 is running valve 2 with 12 minutes remaining and Programme 2 is running valve 3 with 5 minutes remaining.

TIME 12:11
PROG 1 VALVE 2 12:00
PROG 2 VALVE 3 5:00

If you run more than three programmes in parallel then the additional programs are displayed on the next page.

Priority Programme (Option 18)

This allows programme 1 to take priority over other irrigation programmes. If you require this facility set Option 18 to 1. For normal operation set Option 18 to 0.

Irrigation using Volume (Option 19)

The volume facility will allow you to set programmes in litres of water rather than in minutes. The volume facility is designed to operate with flow meters that give a pulse out for every one or ten litres of water. The pulse should be made by the closing of a volt free contact. The minimum open or shut time should not be less than 2 seconds.

To use Volume set Option 19 to 1. Default is 0.

Connecting the Flow Meter

Connect the flow meter across "C2" and "I1", the remote stop input.. Section 8 describes how to use the volume facility.

Continual Cycling Using Remote Start (Option 20)

This option sets Continual Cycling to use the remote start input. Set Option 20 to '1' to allow this facility. If Option 20 is set to 0, continual cycling will ignore the status of the remote start input. Default is 0.

Stop Option (Option 21)

This controls whether irrigation programmes should freeze or permanently stop when the Remote Stop input is active. Set Option 21 to '0' for a Freeze and '1' for a Permanent Stop

Display Output Current (Option 22)

Option 22 display the current that is being drawn from the irrigation controller. Set Option 22 to '1' if you want to display the current. Default is 0.

Disable Automatic Starts (Option 24)

Option 24 allows all automatic starts to be disabled by pressing Select. Set Option 24 to '1' if this is required. Set Option 24 to 0 if this is not required. Default is 0. Section 8.7 describes the use of this feature.

Options 23 to 29 are for Future Use

These options must be set to 0.

Engineering Only (Option 30)- must be set to 0

Engineering Only (Option 32)- must be set to 0

Engineering Only (Option 33)- must be set to 0

